

VERTEX

OPERATOR SET-UP MANUAL FOR VERTEX METAL DETECTORS



FORTRESS
TECHNOLOGY

WWW.FORTRESSTECHNOLOGY.COM

Simple Operation. Outstanding Reliability. Exceptional Performance.

Copyright © 2013 Fortress Technology Inc. All rights reserved. Patent Pending. The information, designs and artwork contained in this document are confidential and may not be disseminated, distributed or copied without written consent from Fortress Technology Inc. Specifications, designs, features and technology subject to change without notice.

Revision History

| <u>VERSION</u> | <u>DESCRIPTION</u> | <u>ISSUE DATE</u> | <u>NAME</u> |
|----------------|---|-------------------|--------------------------|
| 000 | Original layout taken from Gravity Manual 030319. Contents from previous version of gravity manual, updated Wiring Diagrams and menu interface to K040713 | 15 July 2004 | S.Ketchin A Manlangit |
| | | | |
| | | | |
| | | | |
| | | | |
| | | | |
| | | | |
| | | | |
| | | | |

For Assistance Contact Us At:

North & South America:

Fortress Technology Inc.
51 Grand Marshall Drive
Scarborough, Ontario
Canada M1B 5N6

Phone: (416) 754-2898
Fax: (416) 754-2976

Email: fortress@fortresstechnology.com

Vertical Form Fill Seal Applications:

Balanced Coil Technologies, LLC
14535 Industrial Park
Aubrey, TX 76227
USA

Phone : 1-214-389-9351
Fax : 1-214-389-9356

Email : service@balancedcoil.com

Europe:

Fortress Technology Inc.
Unit 15, Beaumont Business Centre
Beaumont Close
Beaumont, UK OX16 1TN

Phone: +44 (0) 1295 256266
Fax: +44 (0) 1295 265277

Email: europe@fortresstechnology.com

Asia, Australia & New Zealand:

Dynamic Inspection Ltd.
17a Cook St.
Cambridge, New Zealand

Phone: 64 011 647 823 4111
Fax: 64 011 647 823 4112

Email: dynamic_inspection@xtra.co.nz

Contents

| | | |
|------------|--|-----------|
| 1.0 | INTRODUCTION..... | 8 |
| 1.1 | DESCRIPTION..... | 8 |
| 1.2 | METAL DETECTION - THE BASIC PRINCIPLES..... | 9 |
| 1.2.1 | <i>Theory Of Operation.....</i> | 9 |
| 1.2.1 | <i>Product Effect and Phasing.....</i> | 10 |
| 1.2.3 | <i>Metal Free Area.....</i> | 11 |
| 1.2.4 | <i>Sensitivity.....</i> | 11 |
| 1.2.5 | <i>Types of Metal.....</i> | 12 |
| 1.2.6 | <i>Shapes & Orientation of Metal.....</i> | 13 |
| 1.4 | HEALTH AND SAFETY..... | 14 |
| 1.4.1 | <i>Health and Safety at Work Act.....</i> | 14 |
| 1.4.2 | <i>Electromagnetic Radiation.....</i> | 14 |
| 1.5 | ASSEMBLY..... | 14 |
| 1.5.1 | <i>Packing List.....</i> | 14 |
| 1.5.1 | <i>Reject Mechanism.....</i> | 14 |
| 1.6 | TYPICAL GUIDELINES..... | 15 |
| 1.6.1 | <i>Prevention.....</i> | 15 |
| 1.6.2 | <i>Sensitivity.....</i> | 15 |
| 1.6.3 | <i>Testing.....</i> | 15 |
| 1.6.4 | <i>Rejected Product Handling.....</i> | 15 |
| 1.6.5 | <i>Record Keeping.....</i> | 15 |
| 2.0 | INSTALLATION..... | 16 |
| 2.1 | LOCATION..... | 16 |
| 2.2 | HANDLING..... | 16 |
| 2.3 | INSTALLATION TOOLS..... | 16 |
| 2.4 | POWER SUPPLY..... | 16 |
| 3.0 | OPERATION..... | 17 |
| 3.1 | DETECTOR DISPLAY AND KEYPAD..... | 17 |
| 3.2 | INITIAL START UP TEST..... | 18 |
| 3.3 | TESTING..... | 18 |
| 3.4 | ROUTINE OPERATION..... | 19 |
| 3.5 | ROUTINE TEST..... | 19 |
| 3.6 | TURNING OFF..... | 19 |
| 3.7.1 | <i>Sensitivity Adjustment.....</i> | 20 |
| 3.7.2 | <i>Calibrate Product Effect.....</i> | 21 |
| 3.7.3 | <i>Reject Timing.....</i> | 21 |
| 3.7.4 | <i>Creating New Product Records.....</i> | 22 |
| 3.7.5 | <i>Password Menu.....</i> | 22 |
| 4. | USER REFERENCE GENERAL..... | 23 |
| | <i>Hard Keys:.....</i> | 23 |
| | <i>Soft Keys:.....</i> | 23 |
| | <i>Editing Option Fields.....</i> | 24 |
| | <i>Editing Numerical and Text Strings.....</i> | 24 |
| | <i>Navigating the Menu System.....</i> | 24 |
| | <i>Conventions.....</i> | 24 |
| 4.1 | MENU LAYOUT DIAGRAM..... | 26 |
| 4.2 | MAIN..... | 28 |
| | FAULT..... | 29 |
| | SENSITIVITY..... | 32 |
| | SELECT PRODUCT..... | 33 |

| | |
|---|-----------|
| PRODUCT EDIT | 34 |
| COPY PRODUCT | 35 |
| DELETE PRODUCT | 36 |
| RESET PRODUCT SETUP | 37 |
| FACTORY SETTINGS | 38 |
| CALIBRATE | 39 |
| DETECTOR POWER SETUP | 41 |
| PHASE MODE HOLD | 42 |
| PHASE TRIGGER | 43 |
| DRY PHASE LIMIT SETUP | 44 |
| WET PHASE LIMIT SETUP | 45 |
| AUTO PHASE SENSITIVITY SETUP | 46 |
| AUTO PHASE SPEED SETUP | 47 |
| PRODUCT HIGH THRESHOLD SETUP | 48 |
| TEST | 49 |
| TEST MODE SETUP | 50 |
| TEST REQUEST REQUIRED PASSES | 51 |
| TEST FAULT SETUP | 52 |
| SELECT UNIT | 53 |
| UNIT SELECTION SETUP | 54 |
| REJECT MENU | 55 |
| REJECT MODE SETUP | 56 |
| REJECT CLOCK | 57 |
| TIME CORRECTION | 58 |
| SLOW CLOCK COMPENSATION | 59 |
| FAST CLOCK COMPENSATION | 60 |
| PHOTO REJECT | 61 |
| PHOTO EYE DISTANCE SETUP | 62 |
| BELT SPEED SETUP | 63 |
| PACKAGE LENGTH SETUP | 64 |
| PHOTO EYE BLOCK LIMIT SETUP | 65 |
| MINIMUM PACKAGE GAP | 66 |
| REJECT WITH NO RUNNING PRODUCT | 67 |
| REJECT CHECK | 68 |
| REJECT CONFIRM POLARITY SETUP | 69 |
| MANUAL REJECT | 70 |
| PASSWORD | 71 |
| CHANGE PASSWORD | 72 |
| PASSWORD HARD KEY ACCESS SETUP | 73 |
| PASSWORD FUNCTION SETUP | 74 |
| DIGITAL FILTER MENU | 75 |
| LANGUAGE SELECTION | 76 |
| PACK COUNT DISPLAY | 77 |
| FAULT SETUP MENU | 78 |
| REJECT ON FAULT MENU | 79 |
| FAULT LATCH MENU | 80 |
| FAULT SOURCE SETTINGS | 81 |
| EXCESS REJECT SETUP | 82 |
| FAULT LOG MENU | 83 |
| APPENDICES | 84 |
| A. Board Maps and Wiring Diagrams..... | 85 |
| DSP MAP Sd003 VER 3 | 85 |
| DISPLAY BOARD | 86 |
| POWER SUPPLY AND WIRE COLOR CODE | 87 |
| TYPICAL INPUT WIRING – Sd003 VER 3.0 | 89 |

| | |
|--|-----------|
| TYPICAL REJECT DEVICE WIRING – SD003 VER 3.0 | 90 |
| B. Troubleshooting Guide | 91 |
| C. Spare Parts List | 92 |
| TYPICAL VERTEX MODEL | 92 |
| SAMPLE REQUEST FORM | 93 |
| E. Equipment History Log | 95 |

1.0 INTRODUCTION

1.1 DESCRIPTION

The **VERTEX** vertical metal detector system uses the latest developments in digital signal processing ensuring complete product integrity. The **Vertex** vertical metal detector system is primarily designed to detect metal contamination in a product that is gravity fed thru a weighing system. The detector is able to phase out the product effect while maintaining a steady sensitivity threshold to detect the metal contaminants. The **Vertex** Vertical metal detector is capable of detecting and rejecting ferrous, non-ferrous and non-magnetic stainless steel.

The package comes in a variety of versions; mostly custom built to suit customer's application, this manual will focus on the standard model. The standard model is a complete system that utilizes the latest digital technology and automated reject mechanism, product transition and search head assembly. The unit is built from aluminium.

Optional attachment for the standard version is a remote control box assembly, communication and data logging capabilities. Additional reject confirmation devices, like alarm and beacon lights are available. The VERTEX system can be custom built to suit application needs.

The product under test is gravity fed from a scale, which travels through the aperture of the detector head. A penetrating electromagnetic field is generated within the detector head, and any metallic contaminant within the detector specification will distort the electromagnetic field and will be detected no matter how deeply embedded in the product.

On detection a reject relay is switched, which in turn initiates the predetermined reject sequence.

Manual Version : MAN-EN-VERTEX-K040713 Revision: 000
Software Version : K040713

1.2 METAL DETECTION - THE BASIC PRINCIPLES

1.2.1 Theory Of Operation

Most modern metal detectors, including the Gravity Model operate on the **balanced coil**, full loop system.

Three coils are wrapped around the aperture through which the product passes. In the centre of the enclosure is the transmitter coil that broadcasts a radio frequency signal and generates an Electro-magnetic field.

Equally spaced on either side of the transmitter coil are two receiver coils (figures 1 & 2).

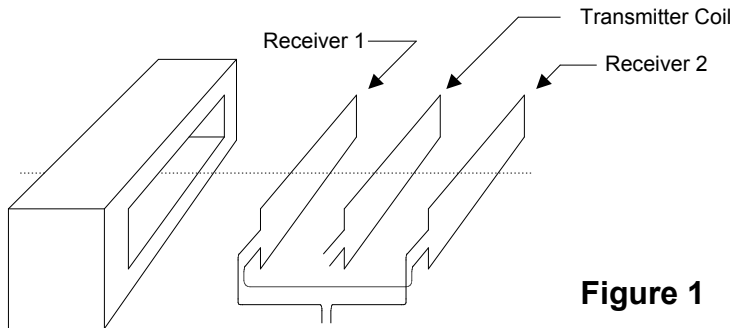

Figure 1

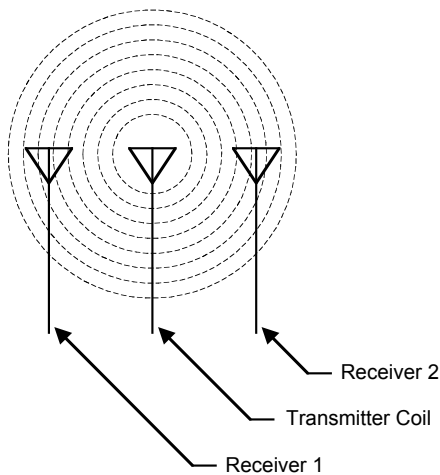

Figure 2

The field is generally trapped inside the shielded enclosure of the detector but some field escapes from the aperture on both sides of the detector. Anything that enters into this field that is either **Magnetic**, or **Electrically Conductive** will cause a disturbance in the field strength around it. All metals have either one or both of these characteristics and will be detectable if the size of the signal is large enough.

The signals from the receiving coils are connected in opposition to each other and therefore when no disturbance is occurring there will be a net signal across the coils of zero – they are balanced. This forms the electrical equivalent of a balanced weigh scale.

As metal passes through the detector the balance will be offset as the contaminant enters the aperture and again as it leaves the exit side. This disturbance is amplified and analysed by the control electronics and detection will occur if the sensitivity threshold has been exceeded.

1.2.1 Product Effect and Phasing

The control electronics actually split the received signal into two separate channels: magnetic and conductive. This means there are effectively two balanced scales within the detector (figure 3). These scales continuously measure the magnetic and conductive signal component of every disturbance. Products that are being inspected can also have one or both of these characteristics.

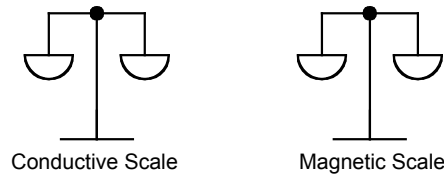

Figure 3

Product Effect

Metal detectors detect metal based on measuring electrical conductivity and magnetic permeability. Many products to be inspected inherently have one or both of these characteristics within their makeup. For example, any product that is iron enriched such as cereals, create a large magnetic signal that the detector must overcome in order to detect small pieces of metal. These are referred to as “dry” products. Conversely, products with high moisture and salt content such as bread, meat, cheese, etc. are electrically conductive and produce a conductive error signal. These are referred to as “wet” products. The table below shows typical product error signals and categorises them as wet or dry.

The detector must remove or reduce this "product effect" in order to identify a metal contaminant. Most modern detectors will have some form of automatic calibration to do this - it is often referred to a *phasing*.

| Typical ‘Wet’ Products | Typical ‘Dry’ Products |
|--|--|
| <p><u>Food</u>: Meat, Cheese, Bread and Bakery Products, Fish, Dairy Products, Salads</p> <p><u>Packaging</u>: Metalized Films</p> <p><u>Other</u>: Plastic and Rubber products with high carbon black content</p> | <p><u>Food</u>: Snack Food, Cereal, Crackers, Flour, Tablets Powders, Biscuits, Frozen Food Products (< -1.0 Degrees C), Peanut Butter and Margarine (Vegetable oil is not conductive)</p> <p><u>Other</u>: Wood Products, Plastics and Rubber (Products with high carbon black content may be considered ‘wet’), Textiles, Paper Products</p> |

1.2.3 Metal Free Area

The Electro-magnetic field is trapped inside the detector's enclosure (shield). However, some field escapes out of the aperture on both sides and forms the metal free area or MFA.

Generally, the size of the practical leakage is about 1.5 times the (smaller) aperture dimension and no metal should be allowed in this area. Large moving metal should be kept 2 x away.

Where applications demand a smaller MFA, special detectors are available which can substantially reduce the total area required.

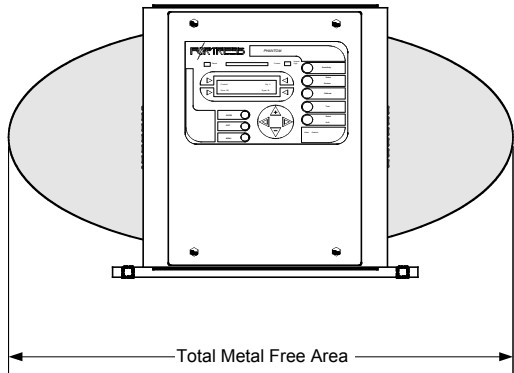

Figure 4

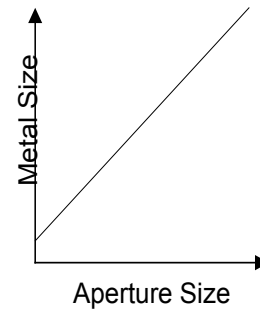

Figure 5

1.2.4 Sensitivity

The *theoretical* sensitivity of a given metal detector is determined by the aperture size. The smaller the aperture, the smaller the piece of metal that can be detected (figure 5). The smaller dimension of rectangular apertures is used to calculate the sensitivity, although the length also contributes.

To maximise sensitivity a detector the smallest size aperture should be selected. However there are some exceptions:

- Metalized Film
- Oxygen Scavengers
- Highly Conductive product (large blocks of cheese)

Product effect, metal free area, type and orientation of contaminant and other factors can affect the *practical* sensitivity in any application.

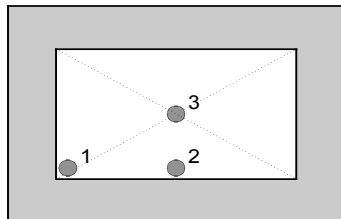

Figure 6

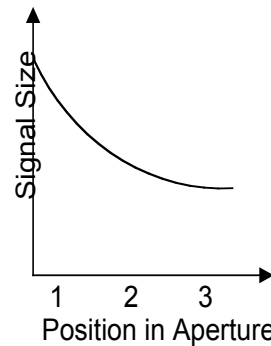

Figure 7

The position in the aperture also affects the sensitivity (see figure 6 & 7). The centre line axis (3) is the least sensitive point and therefore this is where performance testing should take place. As metal gets closer to the sides and coils (1 & 2), the signal it generates gets larger, making it easier to detect.

Regular testing of the detector should be done so that the test ball passes close to the centre of the aperture. If this is not easily done, then a consistent position should be used so that the test results will be consistent

1.2.5 Types of Metal

The sensitivity of a metal detector is not the same for all types of metal. For simplicity, we tend to categorise all metals into three types:

➤ **Ferrous:**

Any metal that can easily be attracted to a magnet (Steel, iron, etc.).

Typically the easiest metal to detect and usually the most common contaminant.

➤ **Non-Ferrous:**

Highly conductive non-magnetic metals (copper, aluminum, brass, etc.)

When inspecting dry products these metals produce almost the same signal size as ferrous due to the fact that they are good conductors.

When inspecting wet products, de-rate the sphere size by at least 50%.

➤ **Non-Magnetic Stainless Steel:**

High quality 300 series stainless steels (Type 304, 316).

These are always the most difficult metals to detect due to their poor electrical conductive qualities and by definition are have low magnetic permeability.

When inspecting dry products a stainless sphere will have to be 50% larger than a ferrous sphere to produce the same signal size.

When inspecting wet products a stainless sphere would have to be 200 to 300 % larger than a ferrous sphere to produce the same signal size.

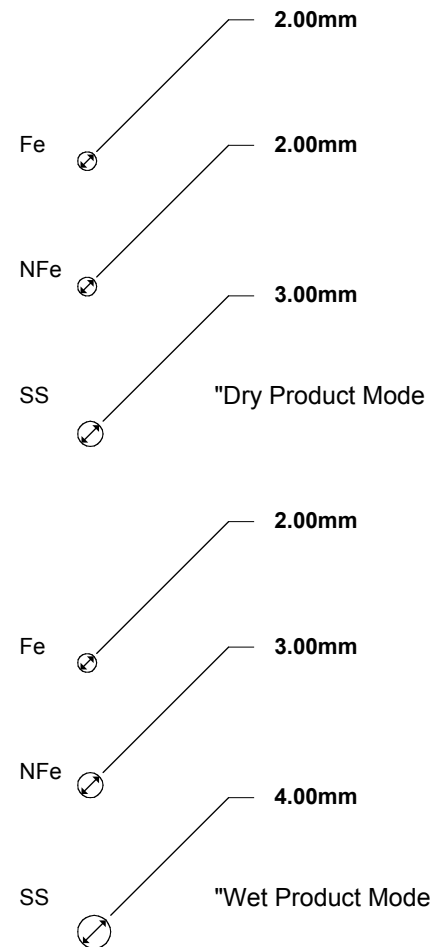

Example of Ratios ONLY

1.2.6 Shapes & Orientation of Metal

Metal detection standards are measured in spheres because a sphere is the same shape from any aspect. Real contaminants are rarely spherical and may produce a different signal depending on its orientation when it passes through the detector. The most dramatic example of this is shown by wire contaminants.

With wire shapes, the signal produced will vary greatly depending on the type of metal and its orientation as it passes through the aperture (see figure 8). In the worst case a wire may produce a signal no bigger than a sphere of the same size as the diameter of the wire.

Ferrous Wires:

- A – Easiest position, biggest signal.
- B, C – Hardest Position, smallest signal.

Non-Ferrous and Stainless Steel Wires:

- B, C – Easiest position, biggest signal.
- A – Hardest position, smallest signal.

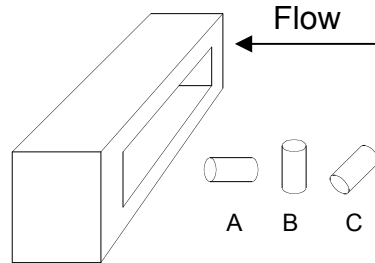

Figure 8

1.4 HEALTH AND SAFETY

1.4.1 Health and Safety at Work Act

The Purchaser shall comply with the instructions and information of this manual, and it is strongly advised that all personnel associated with this equipment be made familiar with the information contained herein.

It is essential that the personnel engaged on the Installation of the plant be competent and experienced in the work. They should comply with the statutory requirements and regulations, including the provisions of the Health and Safety at Work Act, other EU relevant legalisation and relevant OSHA regulations, and in addition to any amendments that may become legal requirements.

1.4.2 Electromagnetic Radiation

This device is an intentional radiator, which complies with Part 15 of the FCC Rules (USA), and relevant legislation under CE Marking. Operation is subject to the following two conditions:

This device may not cause harmful interference.

This device must accept any interference received, including interference that may cause undesired operation.

The equipment generates, uses, and can radiate radio frequency energy and, if not installed and used in accordance with the instruction manual, may cause interference to radio communications.

1.5 ASSEMBLY

All assemblies (i.e. power supply and user interface) required to operate the system are fully wired and ready to be connected to the mains supply.

1.5.1 Packing List

When you receive the Vertex metal detector the following items are included:

- Metal detector test balls. Cards or Wand(s)
- VERTEX Metal Detector System Manual
- Custom plastics and mounting frame where applicable

1.5.1 Reject Mechanism

The reject signal is configured to failsafe. A failsafe reject device will always switch to reject if a problem occurs on the detector i.e. if a power failure occurs. The reject will remain in the reject mode until the detector reverts back to normal operation.

1.6 TYPICAL GUIDELINES

1.6.1 Prevention

- Training for maintenance and cleaning staff in metal detector basics
- Planned & controlled maintenance - possibly non production hours
- Regular inspection - for identification of potential contaminants
- Good housekeeping

1.6.2 Sensitivity

- Identify "standards"
- Re-evaluate standards when conditions change
- Maintain records
- Maximise sensitivity without compromising performance
- Implement security levels - passwords

1.6.3 Testing

- Document & communicate - who & why
- Establish frequency
- Create test packs where relevant

1.6.4 Rejected Product Handling

- Isolate & re-screen potentially contaminated product on test failure
- Investigate source of contaminant - trained personnel, off line & within reasonable time
- On repeat detections, identify source of contaminant
- On multiple detection's stop production

1.6.5 Record Keeping

- Commissioning & sensitivity details
- Test results
- Shift results - number of rejects
- Maintenance schedules
- Training

2.0 INSTALLATION

2.1 LOCATION

The **Vertex** detector is designed to operate in the following environmental conditions:

Environmental Conditions

| | |
|--|----------------------------------|
| Temperature | -5°C to +50°C (23°F to 122°F) |
| Humidity | 100% relative humidity |
| Operating Air Pressure Range | 4 Bar – 8 Bar (60 PSI – 120 PSI) |
| Moisture ingress rating - Metal detector head | Nema 4 / Nema 12 |
| Moisture ingress rating - Electrical Enclosure, Frame, Reject Device | Nema 4 / Nema 12 |

The location of the metal detector is very important. The unit must be positioned on a solid surface to eliminate the transmission of vibration to the detector head. Aperture of the metal detector must be adjusted to suit the existing pipe system.

The metal detector must be positioned in an area free from radiated electromagnetic interference and must be connected to a power supply that is-free from mains borne interference.

2.2 HANDLING

The **Vertex** system weight depends on application. The unit was designed to be robust and specified for washed down application. Framing and plastics are pre designed to accommodate most existing vertical /form /fill /seal applications.

Where the unit has to be lifted we strongly recommended that suitable lifting devices be used.

| |
|---|
| <p style="text-align: center;">WARNING ! Do not use the aperture head as a means of lifting the detector.</p> |
|---|

2.3 INSTALLATION TOOLS

The installation of your **VERTEX** system will only require general tools, there are no special tools required.

2.4 POWER SUPPLY

The metal detector power supply is incorporated within the system electronic enclosure.

The detector internal power supply is universal, working voltage 95-260V AC, 47-63Hz. The power cable should be wired to a suitable plug or device with a circuit protection of 3 amps. Wiring diagram is illustrated in (Appendix A)

WARNING !
Only a suitably qualified electrical technician should wire the Power supply mains cable.
Details of the mains power cable colour coding can be found in Appendix A

3.0 OPERATION

With the detector assembled it is now ready for production. The aim of this section is to describe the operation and the initial tests required before introducing the detector into production.

For more detailed explanation of the software, please consult **Section 4** in this manual.

If problems are encountered during setup, read the troubleshooting section of the manual. (Appendix B)

3.1 DETECTOR DISPLAY AND KEYPAD

Switch on the detector, the display should look similar to that shown below:

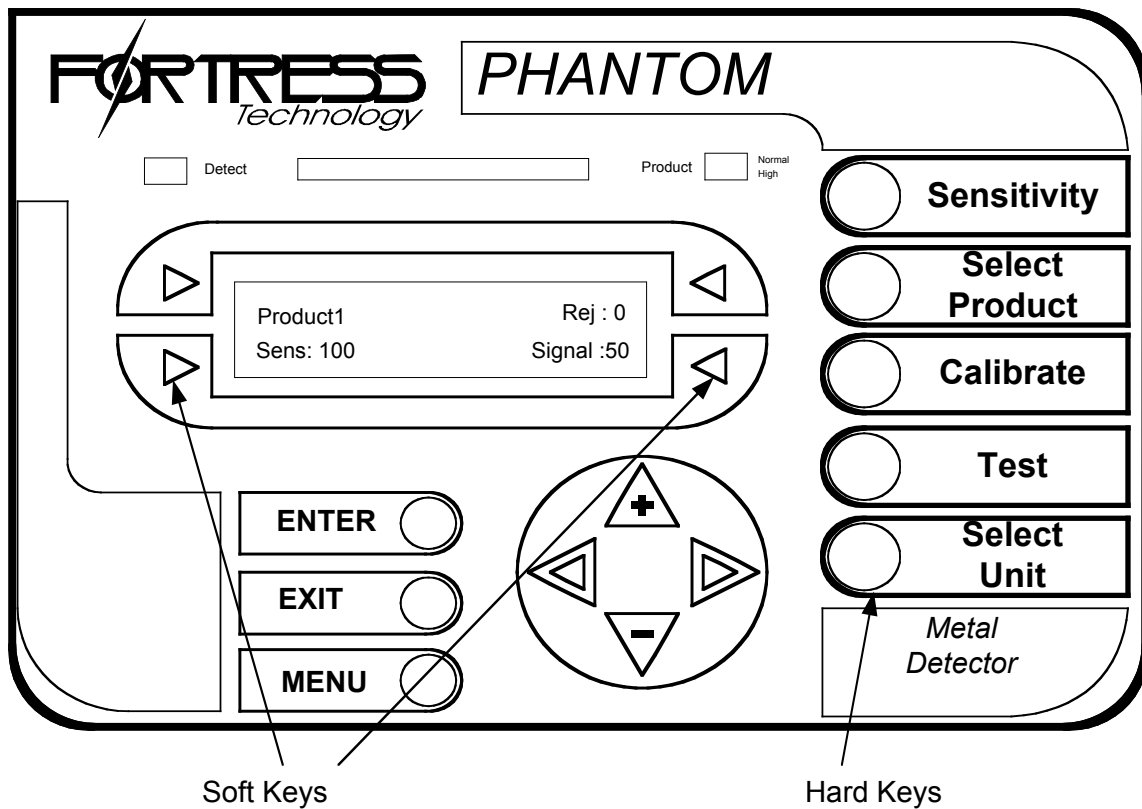

The display has two lines of 20 characters, and after power on the top line shows the current product name and the quantity of rejects.

The second line shows the sensitivity setting and the background signal.

The LED bar graph will settle in the centre within the green zone and can be used together with the product signal to see how good a product setup is and also monitoring the background noise. Note the larger the signal the bigger the effect / contamination that is being detected.

If this signal exceeds 100 then a detection output will occur.

The keypad has a series of '**Hard**' and '**Soft**' Keys.

The Hard keys perform the same function irrespective of where you are within the menu structure and the Soft Keys change their function according to the menu display. For detail of the functions please refer to sections 4.1.1 and 4.1.2 of this manual.

3.2 INITIAL START UP TEST

When power is first applied to the equipment the following sequence of events will occur.

The LED bar graph will go full scale left and right or (right and left), and then return to the normal operating mode of the center LED in the Green Zone. The display will indicate the default menu window. Make sure that the product is running in the gravity system, the unit is power up to enable the metal detector to clearly phase out the effect of the product running through the system.

The reject device will operate and then return to the normal operating position. The power up sequence will take approximately 5 seconds and once complete the detector will be ready for the initial test.

3.3 TESTING

Manual Testing

Follow the standard testing procedure at your facility using the test cards or wands that were provided.

Automatic Testing

The biggest draw back of manual testing is that it is impossible to predict where the test piece will be relative to the aperture of the detector, and for the same reason test results will be inconsistent. For this reason an Automatic Test system can offer advantages.

Detectors capable of Automatic testing can be used to perform short interval testing of the detector and valve reaction without any operator involvement. The use of an automatic reject response check system is also recommended. This involves having a valve position switch feed a confirmation signal back to the detector which can then monitor the response time of the reject device during any reject occurrence.

The **VERTEX** metal detector is shipped with a set of test balls. The metal detector is set during manufacture to detect these test balls and this set up can be found in the **FACTORY SETTINGS**.

| |
|------------------|
| WARNING ! |
|------------------|

Altering the FACTORY TEST SETUP will influence the performance of the metal detector. Consult Fortress Technology before altering this setup.

To test the detector, ensure that the detector is set and calibrated for the product to be run (Refer to Quick set up guide in section 3.7 of manual). Insert the test samples one at a time down the scale funnel, the metal detector should detect the samples.

The detection will be registered on the LED bar graph for units with display and control box, and the reject device will operate.

If it fails to do this repeat procedures 3.7.1 and 3.7.2.

3.4 ROUTINE OPERATION

Product is gravity fed automatically from the output of a weighing machine directly into the collating funnel Vertex metal detector system.

Product that is free from metal contamination will pass through the metal detector system into the packaging machine. When metal is detected the reject sequence will be initiated in the packaging machine.

Rejected products contain the metal contaminants that can be later filtered and process for quality control purposes. Metal contaminants can give indication on where such contaminant is introduced in the system.

3.5 ROUTINE TEST

It is recommended that the sensitivity of the metal detector is checked routinely using the metallic spherical samples embedded in plastic bar provided. In cases where product effect is present, the test samples provided may not be detectable. Larger test samples can be supplied by Fortress Technology upon request.

The routine test is carried out to ensure system integrity and we recommend that it be part of the quality control procedures. In the unlikely event of the detector not detecting the test sample the user must take appropriate action to quarantine the material that has passed through the detector up to the point where the last satisfactory test on the unit was performed.

If the sample was not detected please refer to the faultfinding guide in [Appendix B](#) of this manual.

3.6 TURNING OFF

After the manufacturing process has been completed the detector can be powered off, all product data is retained in the memory.

The detector should be isolated from the mains supply after use.

3.7 Quick Set Up

The following is the suggested order for setting up a Phantom Gravity metal detector.

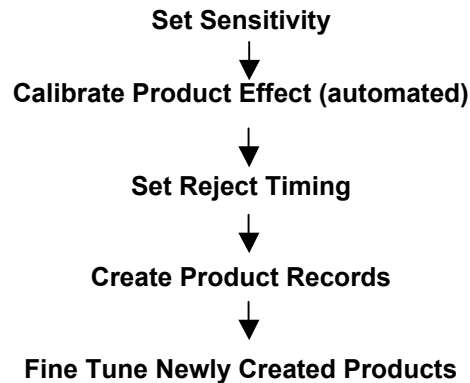

3.7.1 Sensitivity Adjustment

The sensitivity number ranges from 0 to 999, the higher the number the more sensitive the unit will be, the smaller the piece of metal which can be detected. Typically, the sensitivity used will be between 30 and 200. The default figure is usually 100.

The Signal number displayed represents the relative size of the detection signal. To become a detection, a signal must exceed 100. When setting the sensitivity, the signal produced by the test samples should produce a signal of at least 150 and the background product signal should not exceed 60. The signal number will be re-scaled when you adjust the sensitivity. This shows you how big the previous signal will now be.

- To set the sensitivity, press the hard key SENSITIVITY and the display will change to the

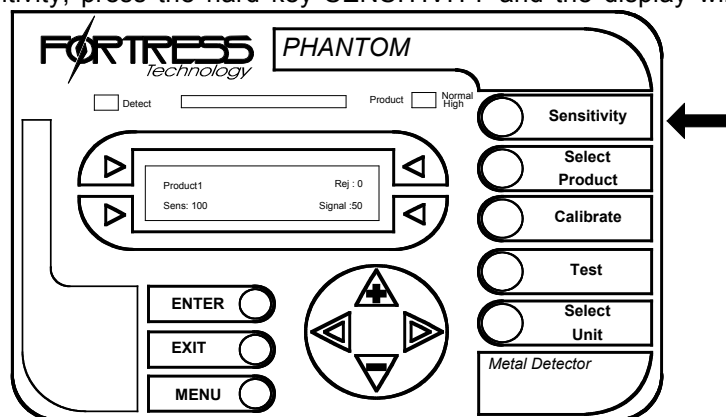

sensitivity menu.

- Press the soft key closest to the sensitivity number and a flashing cursor will appear.

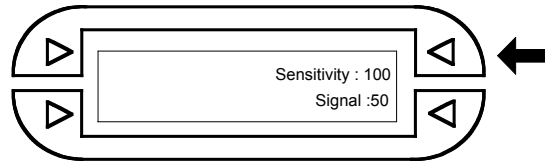

- Press plus or minus to increase or decrease the sensitivity. The cursor can be moved to a more significant digit using the left arrow key.
Adjust the sensitivity so that the background signal is around 40 to 60.

3.7.2 Calibrate Product Effect

The detector will be set with factory settings which may not necessarily match those you need to run for your product.

Pass the product through the detector aperture.

If the detector indicates a detection or the sensitivity scale goes close to, or into, the red you are likely to have a product effect which must be phased out. If the detector does not see the product it is likely that the product you are trying has no product effect.

Typically the product should give a background signal reading of about 60.

- Press the CALIBRATE button and the display will change to the calibrate menu.

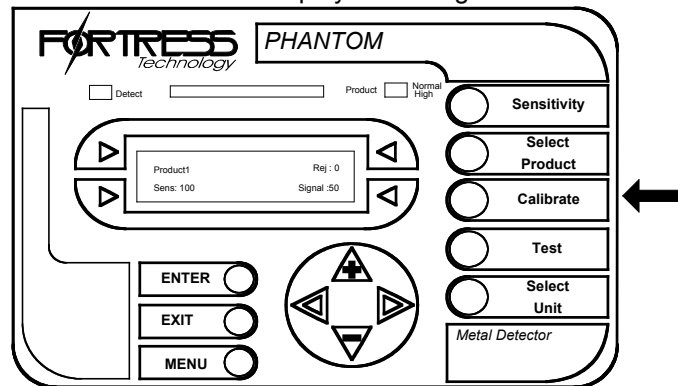

- Press the CALIBRATE button again, and the display will show a "fast" learn mode.

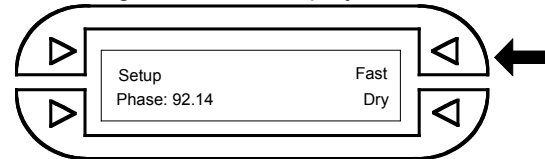

Gravity feed the typical product on the in feed chute of the of the pipe section, The detector will automatically learn the correct phase number of the product. . The display will change to "fixed" and display the adjusted phase angle. The detector should now be set up for the product.

3.7.3 Reject Timing

For this application they settings should already be preset to the following:

Delay time: 0.00 seconds
Duration time: 0.40 seconds

If this is not the case then the following should be carried out:

- Press the MENU key and the display will change to the reject menu.

Adjust the delay number to show 0.00 seconds.

Similarly adjust the duration number to show 0.40 seconds.

3.7.4 Creating New Product Records

It is possible that you will have a number of different products to run that may have different characteristics.

For simplicity, and ease of use, it is always best to fully calibrate at least one product to use as the master and then simply copy it into new product settings.

To create new products press the SELECT PRODUCT key and the display will change to the product menu.

Press the soft key next to the “copy” option and again the display will change to the copy menu.

You can now choose to copy a product record into a new record slot with its own name and number.

Editing Product Names

The product names can be edited just like a number. Use the left and right arrow keys in the circle keypad to move the cursor up or down the word, then use the plus and minus keys to scroll through alpha and numeric characters. Press enter when you are satisfied with the product name you have created.

Selecting Products

To select a product from those you have created, press the SELECT PRODUCT key and the menu will change to the product record menu. To toggle through the list of stored products, press the select product key again. Press enter when the desired product is displayed. The displayed product will be the running product. Make the necessary adjustments for Product Effect, Sensitivity.

| |
|--|
| NOTE: YOU CANNOT DELETE A PRODUCT THAT IS CURRENTLY IN USE |
|--|

Reject Counter

The reject count is displayed in the main display and will increment every reject occurrence. Pressing the soft key associated with the count display can reset it.

Test

To access the test menu, press the Test hard key. To initiate a test signal, press the Test key again. This will inject a simulated metal signal, which can be used to check the detector sensitivity and reject action.

From this menu, an auto test program can be set up. This will inject a simulated metal signal at regular time periods of your choice.

3.7.5 Password Menu

To access password functions, press the Menu twice until the Password menu appears. From this menu you can turn password protection on and off, as well as create a new password.

NOTE: THE DEFAULT PASSWORD IS "AAAA"

To turn password protection on or off, press the top right soft key and a flashing cursor will appear on the on/off option. Press "+" to toggle to the opposite state.

To create a new password, select "Edit" with the soft key and the display will go to the password edit menu. From here you can change the current password. You will be prompted to repeat your password and you should record it in a safe place.

If you forget your password, the detector will display a seed number, which Fortress engineers can decode for you. Please be prepared to offer proof of your authority.

"Logout" is used to tell the detector that you have completed your adjustments and that protection should be reinstated. If password protection is on, it will automatically reinstate itself if a key press has not occurred for some time.

When password protection is on, you will be prompted for the password upon any key press.

Note : A more detailed explanation of the functions and key presses described above can be found in User Reference Section 4.

4. USER REFERENCE GENERAL

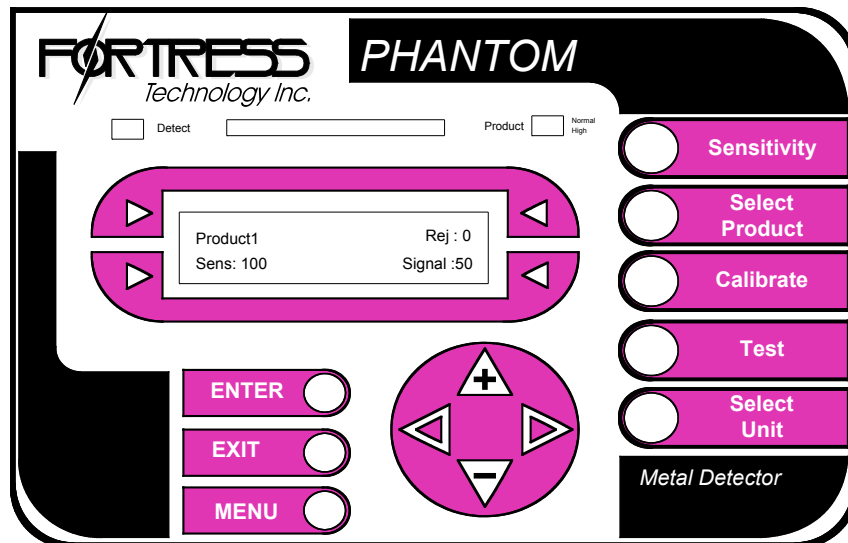

Hard Keys:

The illustration above shows the display panel of the Phantom model metal detector. The most common functions can be accessed by using the dedicated hard keys arranged on the right. Less common functions are accessed through the MENU key.

Soft Keys:

There are also four soft keys arranged around the display that are used to edit the function displayed on the LCD next to that soft key. For example, on the display below, the reject count is displayed next to the top right soft key. To reset the reject counter, simply press that soft key.

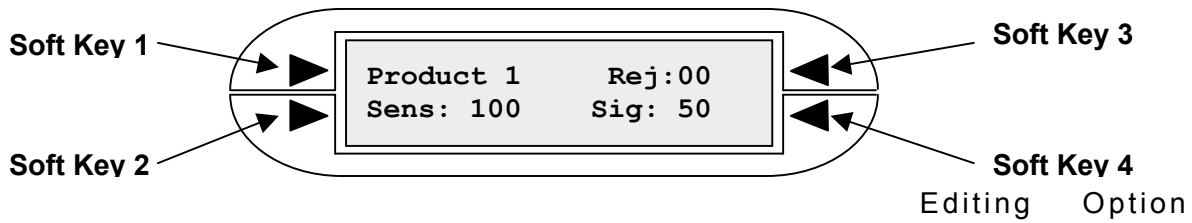

Fields

There are two kinds of option fields:

- Cancellable: After pressing the soft key associated with the option field, a flashing cursor will appear. To cycle through the option press the same soft key again, or use the + and – key located in the circle keypad. To accept the new selection, press the Enter key; to cancel the new selection and revert to the old one, press the Exit key.
- Non-Cancellable: Pressing the soft key will change the selected option immediately.

Editing Numerical and Text Strings

To edit an entry field press the soft key associated with it and a flashing cursor will appear. To edit the content use the + and – key or press the associated soft key again to scroll through the characters, use the left and right arrows to move the cursor across the entry field. When you are satisfied with your entry press the Enter key, to cancel your entry and revert to the old one press the Exit key.

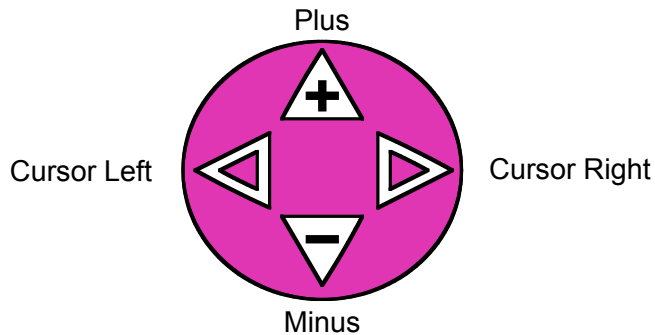

Navigating the Menu System

To move from one menu screen to the next, simply press the MENU key. While no entry field is being edited (i.e. no flashing cursor is visible), one can also press the PLUS key to move to the next menu screen and the MINUS key to move back to the previous menu screen.

Conventions

The following convention will be used throughout the Menu System description to indicate the soft key(s) and the section(s) of the LCD display to which a description refers.

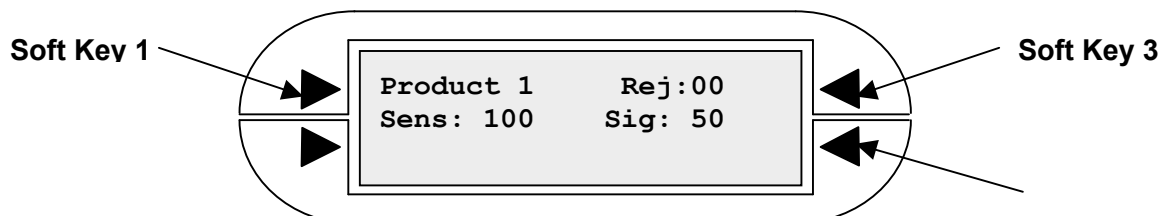

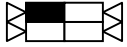

The shaded area indicates which area of the LCD Display is being described. This icon would indicate that the description refers to the top left field of the LCD.

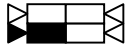

Soft Key 2

This icon indicates that the description refers to the bottom left field of the LCD display. Notice also that the bottom left soft key is also shaded. This indicates that pressing the soft will result in some action by the menu system as described in the accompanying text.

Soft Key 4

4.1 MENU LAYOUT DIAGRAM

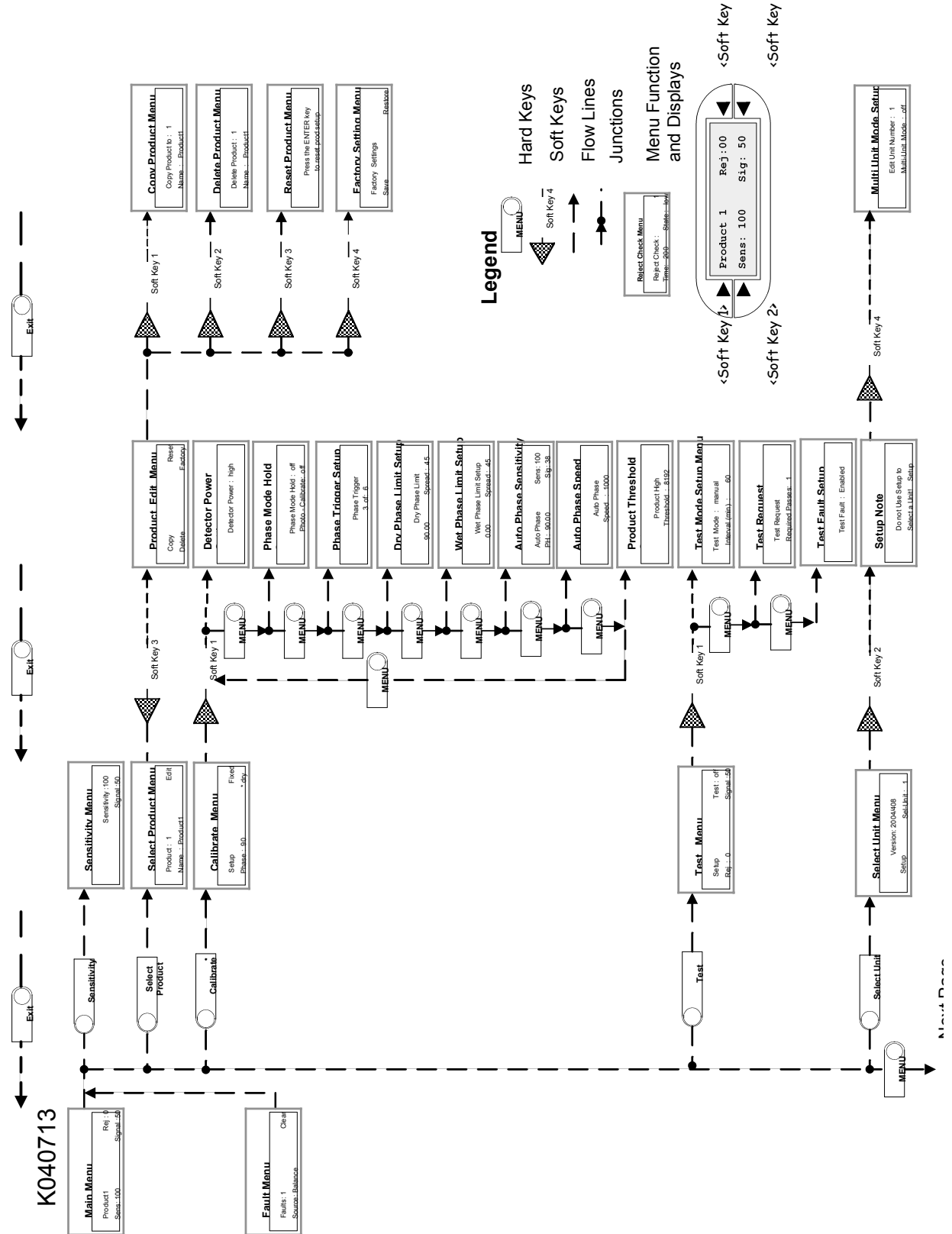

4.2 MAIN

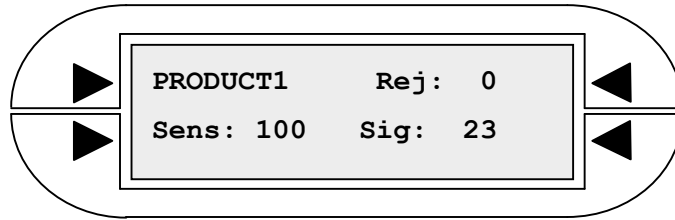

| Soft Key | Function |
|--------------|---------------------------------|
| Top Left | Not used |
| Top Right | Resets the Reject count to zero |
| Bottom Left | Sets the sensitivity |
| Bottom Right | Resets the signal peak |



Selected Product

This field indicates the name of the currently selected product. A different product can be selected by pressing the Select Product hard key to access the Select Product Menu. Products can also be edited, added and deleted from the Select Product Menu.

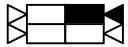

Reject Count (Rej)

This field indicates the reject count. The reject count increments with every reject occurrence.

Press the soft key to reset the reject count.

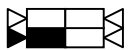

Sensitivity (Sens)

The sensitivity number ranges from 0 to 999, the higher the number the more sensitive the unit will be. In other words smaller pieces of metal can be detected. Typically, the sensitivity used will be between 30 and 200.

Press the soft key to change the sensitivity or press the Sensitivity hard key to access the Sensitivity Menu.

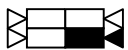

Signal (Sig)

The signal number displayed represents the relative size of the detection signal. To become a detection, a signal must exceed 100. When setting the sensitivity, the signal produced by the test samples should produce a signal of at least 150 and the background product signal should not exceed 60. The peak signal reading will reset every time a detection occurs, displaying the peak value of the signal that caused the detection. It can also be reset manually by pressing the soft key.

Note: The main menu can only be accessed if there are no faults present.

FAULT

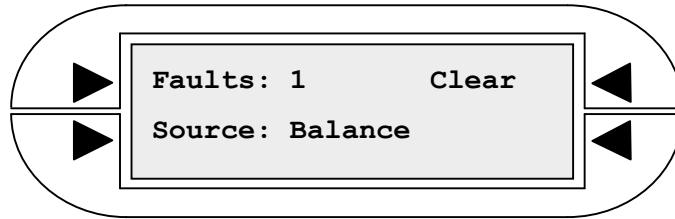

| Soft Key | Function |
|--------------|-----------------------|
| Top Left | Not used |
| Top Right | Clears faults |
| Bottom Left | Cycles through faults |
| Bottom Right | Cycles through faults |

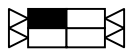

Number of Faults
Indicates the number of faults.

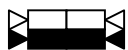

Fault Source
Press one of the soft keys to cycle through the faults if there is more than one fault present.

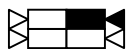

Clearing Faults
Press the soft key to clear the faults, however if a fault is still present it cannot be cleared until the problem is resolved.

Note: Some faults do not need to be cleared, when fixed the fault menu will be replaced by the main menu, assuming there are no other faults present.

List Of Faults:

24V:

- The 24 volt power supply is not functioning properly.
- This fault cannot be cleared by the keypad.
- The 24 volt power supply will have to be checked and/or replaced.

REFERENCE:

- The transmitter reference signal is not being received by the main (digital) circuit board.
- This fault cannot be cleared by the keypad. Check the signals at the search head board or replace the board.

BALANCE:

- The detector balance error is excessive.
- This fault cannot be cleared by the keypad. Check the balance signal level, and check that no metal is located within the detector aperture.

PROD MEMORY:

- The product memory may be corrupt.
- This fault cannot be cleared by the keypad. Cycle power to clear the memory, or reset the product record through the “Reset Product Menu”.

REJECT CHECK:

- The reject confirmation device(s) failed to verify that the contaminated product was properly rejected.
- This fault can be cleared by the “Clear” soft key.
- Check that the reject device is functioning properly and that the confirmation device(s) are positioned correctly.

PHASE LIMIT:

- A phase limit was reached during a calibration or auto phase update.
- This fault can be cleared by the “Clear” soft key.
- Check the phase point, perform a fast phase calibration.

TEST SIGNAL:

- The test signal was not detected properly during a test procedure.
- This fault can be cleared by the “Clear” soft key.
- Check the sensitivity and perform a manual test.

PEYE BLOCKED:

- The infeed photo eye is blocked for an excessive amount of time.
- This fault can be cleared by the “Clear” soft key.
- Check that product is not blocking the infeed area. Check the photo eye for proper function.

REJ POSITION:

- The reject confirm photo eye is blocked for an excessive amount of time.
- This fault can be cleared by the “Clear” soft key.
- Check that a package is not blocking the reject path. Check the reject confirm photo eye for proper function.

AIR PRESSURE:

- The air pressure sensor connected to the Isolated Input of the digital board (PL10 pins 9 and 10) is indicating a low pressure which may impair the proper functioning of the reject device.
- This fault cannot be cleared by the keypad.
- Check the pressure of the air line.

EXCESS REJECT:

- Too many rejects have occurred in a specified time interval.
- This fault can be cleared by the “Clear” soft key.
- Check the rejected product for contaminant metal. Make sure the detector is properly calibrated for the running product.

SENSITIVITY

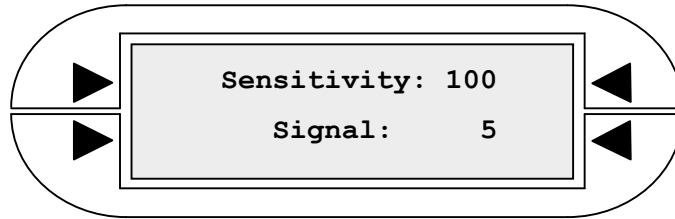

Sensitivity Key

| Soft Key | Function |
|--------------|--------------------------------|
| Top Left | Sets the sensitivity |
| Top Right | Sets the sensitivity |
| Bottom Left | Resets the signal peak reading |
| Bottom Right | Resets the signal peak reading |



Sensitivity Adjustment

The sensitivity number ranges from 0 to 999. The higher the number the more sensitive the unit will be, in other words, smaller pieces of metal can be detected. Typically, the sensitivity used will be between 30 and 200.

Press the soft key to change the sensitivity.



Signal Number

The signal number displayed represents the relative size of the detection signal. To become a detection, a signal must exceed 100. When setting the sensitivity, the signal produced by the test samples should produce a signal of at least 150 and the background product signal should not exceed 60. The peak signal reading will reset every time a detection occurs, displaying the peak value of the signal that caused the detection.

Press the soft key to reset the signal peak.

SELECT PRODUCT

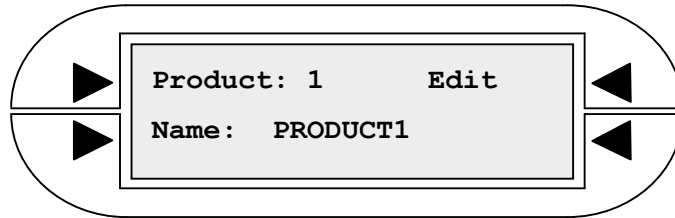

Select Product Key

| Soft Key | Function |
|--------------|---|
| Top Left | Scrolls through the list of stored products |
| Top Right | Goes to the Product Edit Menu |
| Bottom Left | Edits product's name |
| Bottom Right | Edits product's name |

Product List

The Phantom detector can store in memory the settings for up to 32 different products.



Selecting Products

From the Select Product Menu, press the Select Product hard key again to scroll through the list of products or use this soft key.



Renaming Products

Press one of the soft keys to edit the name of the product.

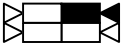

Press the soft key to go to the Product Edit Menu.

PRODUCT EDIT

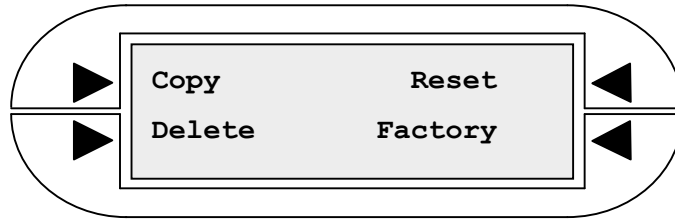

Select Product Key > Soft Key 3

| Soft Key | Function |
|--------------|----------------------------------|
| Top Left | Goes to the Copy Product Menu |
| Top Right | Goes to Reset Product Setup Menu |
| Bottom Left | Goes to Delete Product Menu |
| Bottom Right | Goes to Factory Settings Menu |

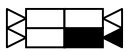

Press the soft key to go to the Factory Settings Menu

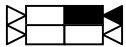

Press the soft key to go to the Reset Product Setup Menu

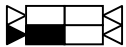

Press the soft key to go to the Delete Product Menu

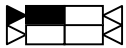

Press the soft key to go to the Copy Product Menu

COPY PRODUCT

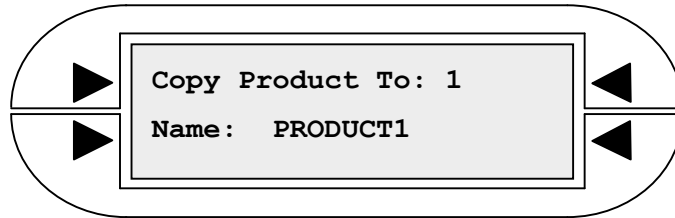

Select Product Key > Soft Key 3 > Soft Key 1

| Soft Key | Function |
|--------------|--|
| Top Left | Sets the number of the new product |
| Top Right | Sets the number of the new product |
| Bottom Left | Edits the name of the currently selected product |
| Bottom Right | Edits the name of the currently selected product |

Creating New Product Records (copying)

When creating new product records, a copy of an existing record will be created in a new product slot. Then you can make any adjustment to the new product settings. For this reason, it is best to fully calibrate at least one product to use as the master and copy into new product settings.



To create a new product, press the soft key to select the number of the new product, and then press the Enter key.

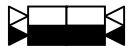

After pressing the Enter the key, you can edit the name entry field by pressing the associated soft keys.

DELETE PRODUCT

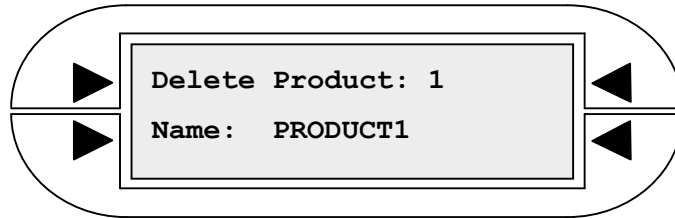

Select Product Key > Soft Key 3 > Soft Key 2

| Soft Key | Function |
|--------------|--|
| Top Left | Sets the number of the product to be deleted |
| Top Right | Sets the number of the product to be deleted |
| Bottom Left | Not used |
| Bottom Right | Not used |



Deleting products

To delete a product setting, edit the entry field to select the number of the product you want to delete. After pressing the Enter key, the name of the product will change to UNDEFINED to confirm that the product has been deleted.

RESET PRODUCT SETUP

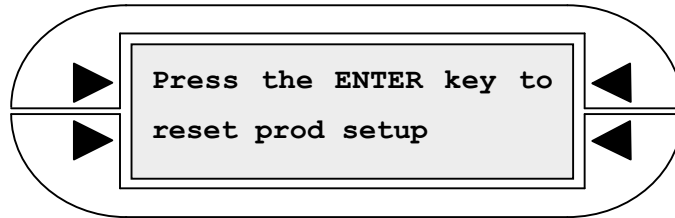

Select Product Key > Soft Key 3 > Soft Key 3

| Soft Key | Function |
|--------------|----------|
| Top Left | Not used |
| Top Right | Not used |
| Bottom Left | Not used |
| Bottom Right | Not used |



Pressing the ENTER resets the current product settings to standard settings. These settings are always the same. This is used when many changes were made to the settings and you want to return to a known starting point.

FACTORY SETTINGS

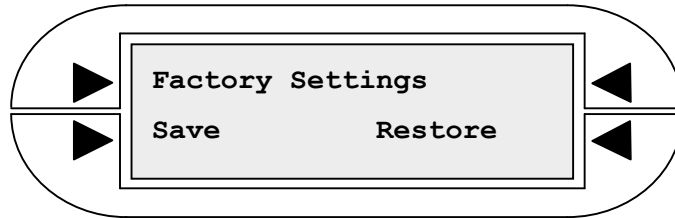

Select Product Key > Soft Key 3 > Soft Key 4

| Soft Key | Function |
|--------------|---------------------------|
| Top Left | Not used |
| Top Right | Not used |
| Bottom Left | Saves Factory Settings |
| Bottom Right | Restores Factory Settings |

Factory Settings

The factory settings are a product record that can be set by Fortress Technology or the customer. These settings can be copied into the current product record as a typical starting point by pressing the Restore soft key. Once a good setup is determined for the typical product this can be saved into the factory record using the save soft key.

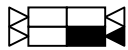

Press the soft key to restore the factory settings to the current product.

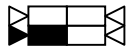

Press the soft key to save the current product settings to the factory settings.

CALIBRATE

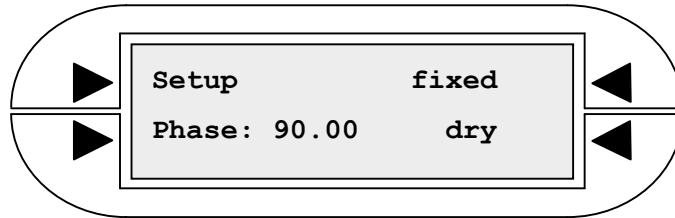

Calibrate Key

| Soft Key | Function |
|--------------|----------------------------------|
| Top Left | Goes to the Phase Mode Hold menu |
| Top Right | Cycles through calibration modes |
| Bottom Left | Sets the phase |
| Bottom Right | Cycles through the phasing modes |

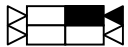

Phase Speed

There are three Phasing modes:

- Fast - This will start a product learn process which will learn the phase point of the test product.
- Auto - In this mode the detector will slowly adapt the phase point automatically as products pass through the aperture.
- Fixed - The phase point will be fixed to its current value.

Press the soft key to edit change the phasing mode.

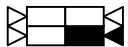

Phase Compensation

- Wet - In wet mode, the detector will compensate for conductive product effects. The phase point of most wet product is near 0.
- Dry - In dry mode, the detector will compensate for magnetic (reactive) product effects. The phase point of most dry products is near 90.

Press the soft key to change the type of phase compensation.

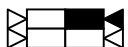

Calibrate Product Effect

To calibrate for product effect, (see below) press the 'Calibrate' hard key and the display will change to the calibrate menu. Press the 'Calibrate' hard key again, and the display will show a "fast" learn mode. Run a typical product through the detector at normal belt speed, and the detector will automatically find the correct phase value. Please read the section below describing product effect prior to performing a learn function.

Product Effect

Metal detectors detect metal based on measuring electrical conductivity and magnetic permeability. Many products to be inspected inherently have one or both of these characteristics within their makeup. For example, any product that is iron enriched such as cereals, create a large magnetic signal, which the detector must compensate for in order to detect small pieces of metal. Conversely products with high moisture such as bread, meat, cheese,

etc., are electrically conductive and produce a large conductive signal. These are referred to as “wet” products. During a fast learn process, the Phantom detector automatically sets its phase point to ignore the product effect signal. The table below shows typical product effect signals and categorizes them as wet or dry.

| Typical ‘Wet’ Products | Typical ‘Dry’ Products |
|---|--|
| <p><u>Food:</u> Meat, Cheese, Bread and Bakery Products, Fish, Dairy Products, Salads</p> <p><u>Packaging:</u> Metallized Films</p> <p><u>Other:</u> Plastic and Rubber products with high carbon black content</p> | <p><u>Food:</u> Cereal, Crackers, Cookies, Frozen Food Products (< 20 Degrees F), Peanut Butter and Margarine (Vegetable oil is not conductive)</p> <p><u>Other:</u> Wood Products, Plastics and Rubber (Products with high carbon black content may be considered ‘wet’), Textiles, Paper Products</p> |

DETECTOR POWER SETUP

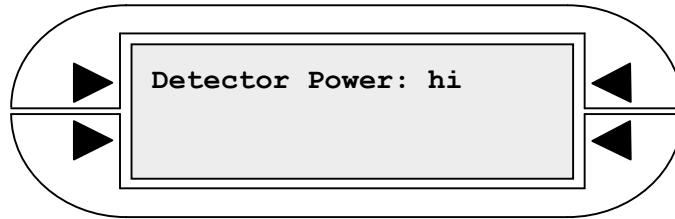

Calibrate Key > Soft Key 1

| Soft Key | Function |
|--------------|-------------------------------|
| Top Left | Not used |
| Top Right | Toggles Detector Power hi/low |
| Bottom Left | Not used |
| Bottom Right | Not used |

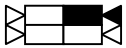

Detector Power Setup

Toggling the Detector power from “hi” to “low” will reduce the power of the detector for product that has large product effect i.e. product with metalized film wrapper. The default setting of the detector power is “hi”

PHASE MODE HOLD

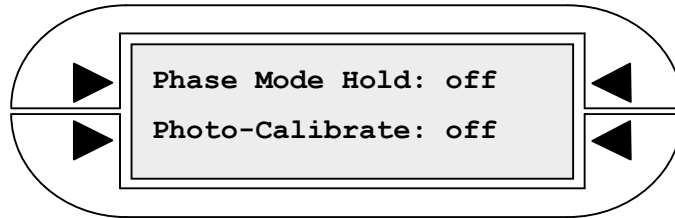

Calibrate Key > Soft Key 1

| Soft Key | Function |
|--------------|---------------------------------------|
| Top Left | Not used |
| Top Right | Sets phase mode hold On/Off |
| Bottom Left | Not used |
| Bottom Right | Sets Photo-Calibrate mode hold On/Off |

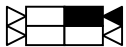

Phase Mode Hold

Setting Phase Mode Hold to “on” will prevent the phase mode from changing during a phase learn. The phase mode will not be allowed to change from wet to dry or dry to wet.

If your product is always dry or always wet but not both, then this should be “on”.

Press the soft key to turn Phase Mode Hold ON or OFF.

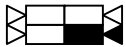

Photo-Calibrate

Setting Photo-Calibrate to “on” will tell the detector to use the infeed photo eye to wait for the next package and calibrate the phase to that package in a single pass.

Note: Photo-calibrate requires an infeed photo eye.

Press the soft key to turn Photo-Calibrate ON or OFF.

PHASE TRIGGER

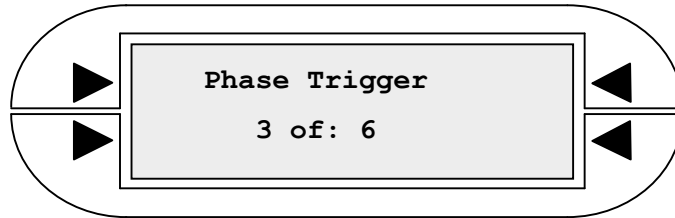

Calibrate Key > Soft Key 1 > Menu Key

| Soft Key | Function |
|--------------|-------------------------------|
| Top Left | Not used |
| Top Right | Not used |
| Bottom Left | Edits the number on the left |
| Bottom Right | Edits the number on the right |

Phase Trigger

This menu is used to set the ratio, of rejected products versus products that went through the detector, that will trigger a phase learn. For example the screen shot above indicates that if 3 out of 6 products result in a reject then a phase learn will be triggered. This only applies when the unit is in auto-phase mode. (See Calibrate Menu) When in fixed phase mode, this menu has no effect.



Press one of the soft keys to change the ratio that will trigger a phase learn.

DRY PHASE LIMIT SETUP

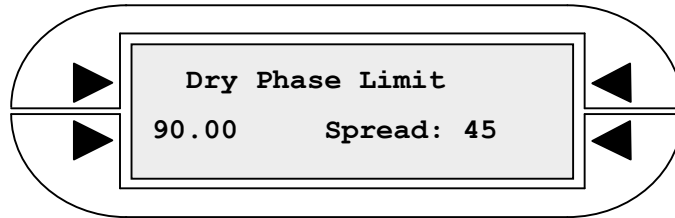

Calibrate Key > Soft Key 1 > Menu Key X 2

| Soft Key | Function |
|--------------|----------------------------------|
| Top Left | Not used |
| Top Right | Not used |
| Bottom Left | Edits the phase angle |
| Bottom Right | Edits the dry phase spread limit |

Dry phase Limit

This menu is used to limit the range of the phase angle learn. The number on the left is the average phase point of the product. The number on the right is the spread around this phase point. For example, the phase point will be limited to 90.00 ± 45 degrees, in the screen shot shown above.

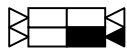

Press the soft key to edit the dry phase spread limit

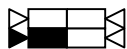

Press the soft key to edit the phase angle

WET PHASE LIMIT SETUP

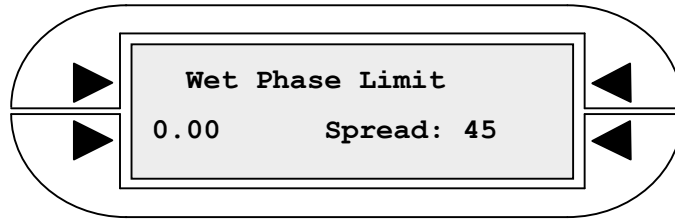

Calibrate Key > Soft Key 1 > Menu Key X 3

| Soft Key | Function |
|--------------|----------------------------------|
| Top Left | Not used |
| Top Right | Not used |
| Bottom Left | Edits the phase angle |
| Bottom Right | Edits the wet phase spread limit |

Wet Phase Limit

This menu is used to limit the range of the phase angle learn. The number on the left is the average phase point of the product. The number on the right is the spread around this phase point. For example, the phase point will be limited to 0.00 ± 45 degrees, in the screen shot shown above

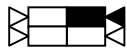

Press the soft key to edit the wet phase spread limit

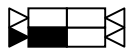

Press the soft key to edit the phase angle

AUTO PHASE SENSITIVITY SETUP

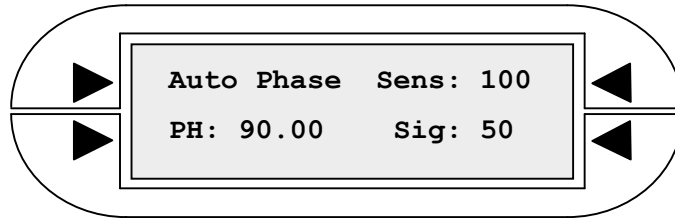

Calibrate Key > Soft Key 1 > Menu Key X 4

| Soft Key | Function |
|--------------|---|
| Top Left | Not used |
| Top Right | Edits the auto phase sensitivity |
| Bottom Left | Edits the auto phase defaulted to 90.00 degrees |
| Bottom Right | Not used |

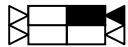

Auto Phase Sensitivity

The sensitivity number controls how sensitive the metal detector is to determine the phase point that will be adapted during a product run. A larger number speeds up the adaptation. Please call Fortress Technology for technical assistance before editing this number.

AUTO PHASE SPEED SETUP

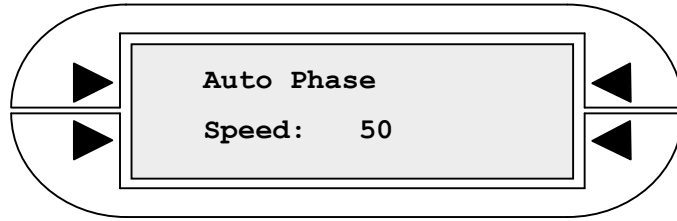

Calibrate Key > Soft Key 1 > Menu Key X 5

| Soft Key | Function |
|--------------|----------------------------|
| Top Left | Not used |
| Top Right | Not used |
| Bottom Left | Edits the auto phase speed |
| Bottom Right | Edits the auto phase speed |

Auto Phase Speed

The speed number controls how quickly the phase point will be adapted during a product run. A larger number speeds up the adaptation. Please call Fortress Technology for technical assistance before editing this number.

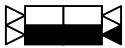

Press the soft key to change the speed.

PRODUCT HIGH THRESHOLD SETUP

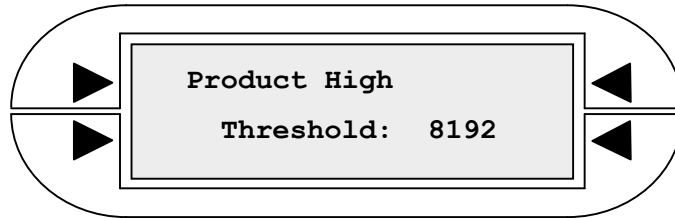

Calibrate Key > Soft Key 1 > Menu Key X 5

| Soft Key | Function |
|--------------|-----------------------------------|
| Top Left | Not used |
| Top Right | Not used |
| Bottom Left | Not used |
| Bottom Right | Edits the Product high threshold. |

Product High Threshold

This number controls the threshold level of the product effect signal. If the product effect exceeds this threshold, the "Product High" light will turn red on the control panel. This indicates that the frequency and or the oscillator power may need to be reduced for this product. Please call Fortress Technology for assistance

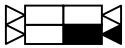

Press the soft key to edit the product high threshold

TEST

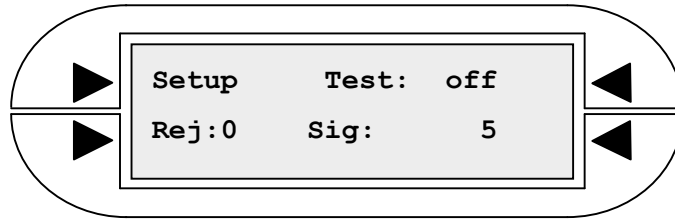

Test Key

| Soft Key | Function |
|--------------|-----------------------------|
| Top Left | Goes to Test Setup Menu |
| Top Right | Tests unit |
| Bottom Left | Resets reject count to zero |
| Bottom Right | Resets signal peak |

Testing the Detector

The test function can be used to test the detector's sensitivity and the reject device. This injects a hardware signal of a magnitude and phase that would have been produced by a test metal sample passing through the detector. It tests all of the electronics. If the test signal does not cause a detection, a fault is generated. The detector can automatically perform tests at regular time intervals. See the Test Setup Menu for more details.

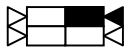

To initiate a test signal, press the Test hard key or this soft key.

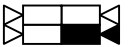

Pressing the soft key will reset the signal peak.

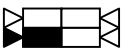

Pressing the soft key will reset the test reject counter

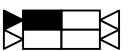

Pressing the soft key will bring up the Test Setup Menu

TEST MODE SETUP

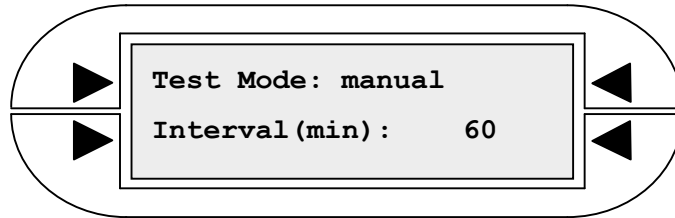

Test Key > Soft Key 1

| Soft Key | Function |
|--------------|---|
| Top Left | Not used |
| Top Right | Cycles through test modes |
| Bottom Left | Not used |
| Bottom Right | Sets interval of time between each automatic test |

Test Modes

This menu is used to select manual test, automatic test or a test request.

- Manual – The detector will be tested only when a user triggers the test function by pressing the Test hard key.
- Auto – The detector will perform a test automatically at regular intervals.
- Request – The detector will request a test automatically at regular intervals by activating output 1. This output can be wired to a beacon. The detector will display a screen, which asks the QA person to acknowledge the request.

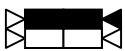

Press the soft key to select between manual automatic and request testing.

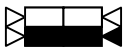

Press the soft key to edit the testing interval.

TEST REQUEST REQUIRED PASSES

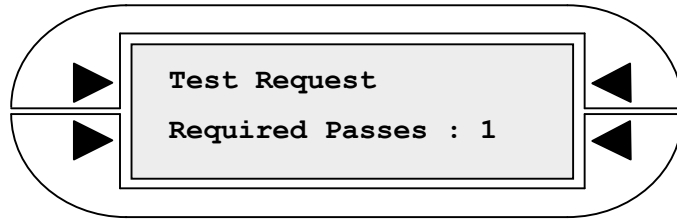

Test Key > Soft Key 1 > Menu Key X 2

| Soft Key | Function |
|--------------|---------------------------------|
| Top Left | Not used |
| Top Right | Not used |
| Bottom Left | Not used |
| Bottom Right | Adjust value of required passes |

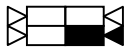

Test Request Required Passes

Press soft key 4 to move the cursor on the number, and press the + and – sign to increase or decrease the number of required passes for a manual test to be successful.

TEST FAULT SETUP

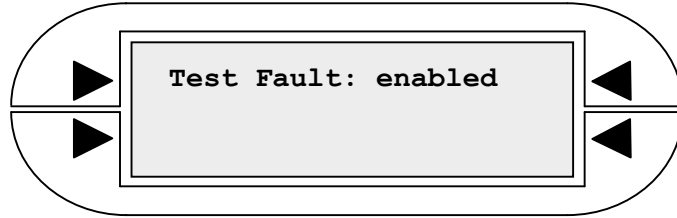

Test Key > Soft Key 1 > Menu Key

| Soft Key | Function |
|--------------|-----------------------------|
| Top Left | Not used |
| Top Right | Enables/Disables Test Fault |
| Bottom Left | Not used |
| Bottom Right | Not used |

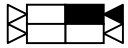

Test fault

Enabled - Test faults will be displayed.

Masked - Test faults will not be displayed.

Press the soft key to enable or disable the test fault.

SELECT UNIT

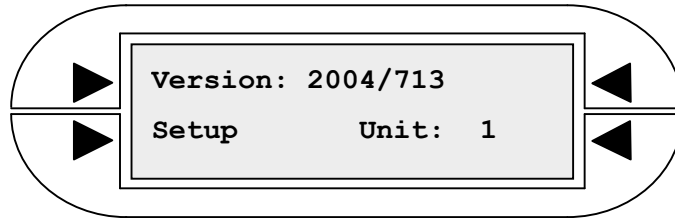

Select Unit Key

| Soft Key | Function |
|--------------|---|
| Top Left | Not used |
| Top Right | Not used |
| Bottom Left | Goes to Unit Selection Setup Menu |
| Bottom Right | Selects a metal detector by unit number |



Version Date

This indicates the date that this software version was created.

Unit Number

Up to 32 Phantom detectors can be controlled from a single display panel.

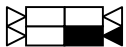

Press the soft key to change the Unit number.

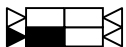

Press the soft key to go to the Unit Selection Setup Menu.

UNIT SELECTION SETUP

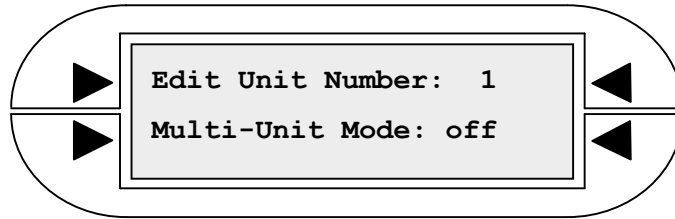

Select Unit Key > Soft Key 2

| Soft Key | Function |
|--------------|-----------------------------|
| Top Left | Edit the unit number |
| Top Right | Edit the unit number |
| Bottom Left | Sets Multi-Unit Mode On/Off |
| Bottom Right | Sets Multi-Unit Mode On/Off |



Edit Unit Number

Before multiple units can be connected to one display panel, each one must be assigned a different unit number.

For more information on how to set up units for Multi-Unit mode, refer to the document "Multi-Unit Control Manual For Fortress PHANTOM Digital Metal Detectors".

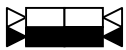

Multi-Unit Mode

Use one of the soft keys to turn the Multi-Unit Mode on or off.

REJECT MENU

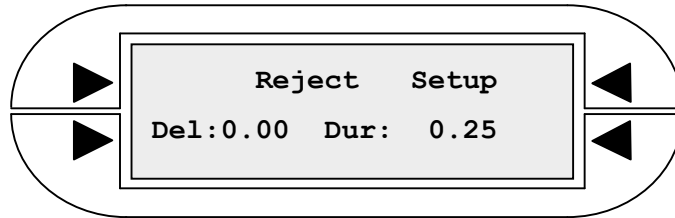

Menu Key

| Soft Key | Function |
|--------------|--|
| Top Left | Not used |
| Top Right | Goes to the Reject Setup Menu |
| Bottom Left | Sets the Reject Delay time in seconds or encoder pulses |
| Bottom Right | Sets the Reject Duration time in seconds or encoder pulses |

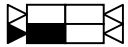

Reject Delay (Del)

The reject delay time refers to the amount of time the detector will wait before activating the reject device after a detection has occurred. The time is shown in seconds when an internal reject clock is used and encoder-pulses when an external reject clock (e.g. a shaft encoder) is used.

Press the soft key to edit the reject delay.

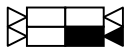

Reject Duration (Dur)

The reject duration refers to the amount of time in seconds the reject device will remain activated once activated. The time is shown in seconds when an internal reject clock is used and encoder-pulses when an external reject clock (e.g. a shaft encoder) is used.

Press the soft key to edit the reject duration.

REJECT MODE SETUP

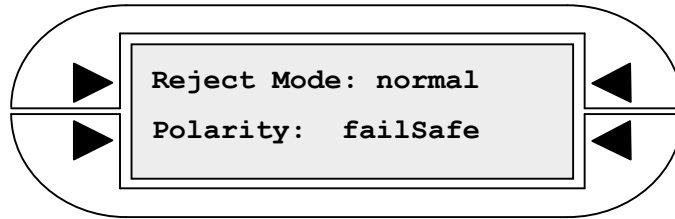

Menu Key > Soft Key 3

| Soft Key | Function |
|--------------|---------------------------------|
| Top Left | Not used |
| Top Right | Cycles through the Reject modes |
| Bottom Left | Cycles Reject Polarity |
| Bottom Right | Cycles Reject Polarity |

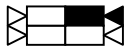

Reject Mode

- Normal – The reject device will be activated according to the reject delay and the reject duration times.
- Photo – Photo-registered mode uses an infeed photo eye to keep track of the position and size of all discrete packages that pass through the detector. In this way, the detector can reject contaminated packages with greater accuracy.
- Reverse – Products that do not cause a detection will be rejected. An infeed photo eye is required for this reject mode.

Press the soft key to change the reject mode.

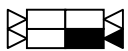

Polarity

- Fail Safe – The coil of the reject relay is normally energized. A detection will de-energize the reject device. Therefore, the reject device will move to its reject position if the power to the detector is removed.
- Not Fail Safe – The coil of the reject relay is energized only when a detection occurs. The reject device may not be in the reject position if the power to the detector is removed.

Press the soft key to toggle between Fail Safe and Not Fail Safe mode.

REJECT CLOCK

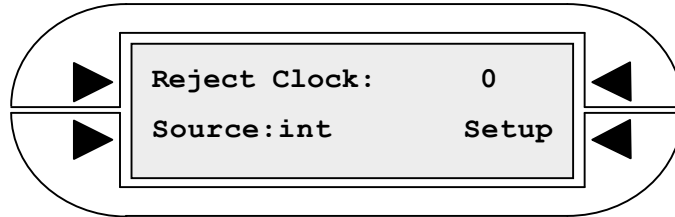

Menu Key > Soft Key 3 > Menu Key

| Soft Key | Function |
|--------------|--------------------------------------|
| Top Left | Not used |
| Top Right | Not used |
| Bottom Left | Changes the reject clock source |
| Bottom Right | Jumps to the Reject Travel Time Menu |

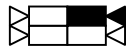

Reject Clock:

This displays the frequency (in Hertz) of the **external** clock source.

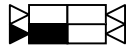

Source:

The timing for the reject device can be controlled from two sources:

Internal Clock (int) - An internal digital clock is used for the reject timing.

External Clock (ext) - An external device is used for the reject timing.
Examples of such devices are shaft encoders and flow meters.

Press the soft key to change the reject timing source.

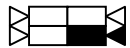

Setup:

Jump to the Reject Travel Time Menu. This is only required when an external clock source is used.

TIME CORRECTION

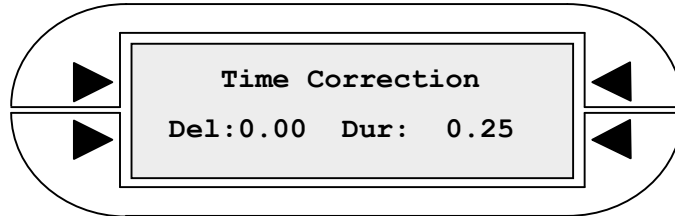

Menu Key > Soft Key 3 > Menu Key > Soft Key 4

| Soft Key | Function |
|--------------|-----------------------------|
| Top Left | Jumps to clock compensation |
| Top Right | Not Used |
| Bottom Left | Not used |
| Bottom Right | Not used |



Reject Travel Time (Time Correction)

This parameter is only used with an external clock source such as a shaft encoder. It is used to compensate for a slow reject device when the belt speed varies by a large amount. These values are learned using the correction submenus.

Press the soft key to enter the reject time correction sub menu.

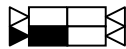

Delay (Del)

Display the computed reject travel time delay correction.

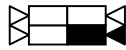

Duration (Dur)

Display the computed reject travel time duration correction.

Time Correction Graph

Reject Delay pulses

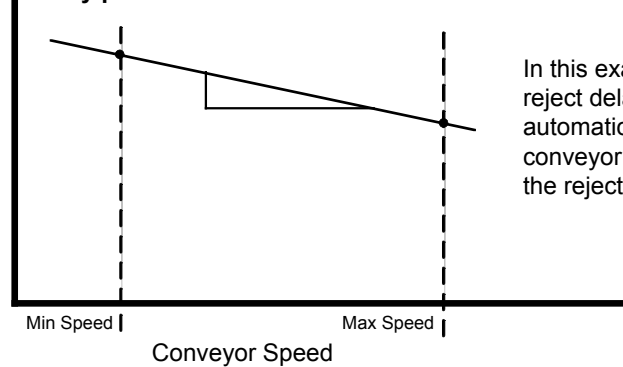

In this example, the number of reject delay encoder pulses is automatically decreased at higher conveyor speeds to compensate for the reject travel time.

SLOW CLOCK COMPENSATION

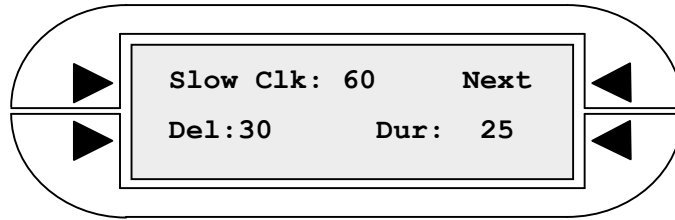

Menu Key > Soft Key 3 > Menu Key > Soft Key 4 > Soft Key 1

| Soft Key | Function |
|--------------|---|
| Top Left | Display the slow speed encoder pulse rate |
| Top Right | Jumps to next clock compensation |
| Bottom Left | Sets the Reject Delay time in encoder pulses |
| Bottom Right | Sets the Reject Duration time in encoder pulses |

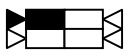

Slow Clock

Display the current clock reading. When adjusting delay and duration, set conveyor speed to the slow production setting.

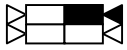

Next

Press the soft key after adjusting the delay and duration values for the slow conveyor speed

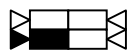

Reject Delay (Del)

The reject delay time refers to the amount of time the detector will wait before activating the reject device after detection has occurred. The time is shown in encoder-pulses.

Press the soft key to edit the reject delay.

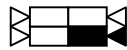

Reject Duration (Dur)

The reject duration refers to the amount of time in seconds the reject device will remain activated once activated. The time is shown in encoder-pulses.

Press the soft key to edit the reject duration.

FAST CLOCK COMPENSATION

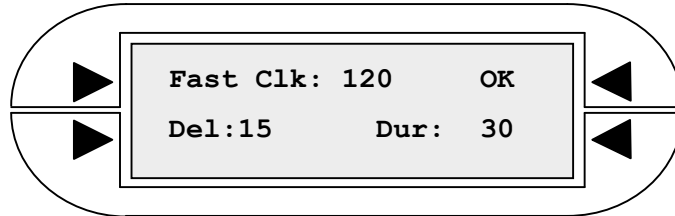

Menu Key > Soft Key 3 > Menu Key > Soft Key 4 > Soft Key 1 > Menu key

| Soft Key | Function |
|--------------|---|
| Top Left | Display the high speed encoder pulse rate |
| Top Right | Compute the time corrections and display the new values |
| Bottom Left | Sets the Reject Delay time in encoder pulses |
| Bottom Right | Sets the Reject Duration time in encoder pulses |



Fast Clock

Display the current shaft encoder pulse rate. When adjusting delay and duration, set conveyor speed to the fast production setting.



OK

Compute the time corrections and display the new values.

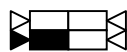

Reject Delay (Del)

The reject delay time refers to the amount of time the detector will wait before activating the reject device after detection has occurred. The time is shown in encoder-pulses.

Press the soft key to edit the reject delay.

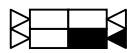

Reject Duration (Dur)

The reject duration refers to the amount of time in seconds the reject device will remain activated once activated. The time is shown in encoder-pulses.

Press the soft key to edit the reject duration.

PHOTO REJECT

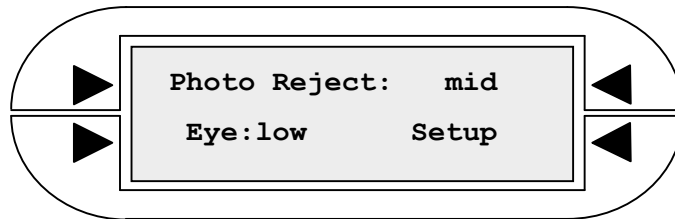

Menu Key > Soft Key 3 > Menu Key X 2

| Soft Key | Function |
|--------------|---------------------------------------|
| Top Left | Not used |
| Top Right | Cycles through photo eye status |
| Bottom Left | Toggles hi/low photo eye normal state |
| Bottom Right | Goes to Photo Reject Setup |

Photo-Registered Reject Timing

Photo-registered reject timing uses an infeed photo eye to keep track of the position and size of all discrete products that pass through the detector. In this way, the detector can reject contaminated packages with greater accuracy.



Eye

Press the soft key to invert the polarity of the photo eye so that the following is achieved.

Low – Photo eye not blocked by package.

Hi – Photo eye blocked by package.



Photo eye package registration

Leading (lead) – Aims the reject device to hit the leading edge of the package

Middle (mid) – Aims the reject device to hit the middle of the package. This feature compensates for small or large bags

Width – The reject device will be activated for the entire width of the package

Press the soft key to change the photo reject mode.

PHOTO EYE DISTANCE SETUP

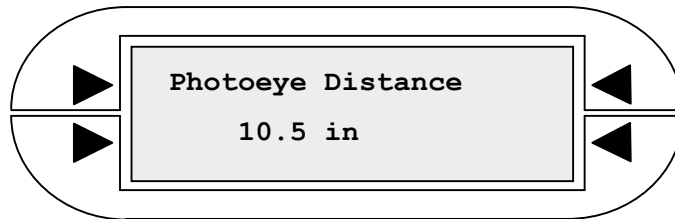

Menu Key > Soft Key 3 > Menu Key X 2 > Soft Key 4 > Menu Key X 2

| Soft Key | Function |
|--------------|--|
| Top Left | Not used |
| Top Right | Not used |
| Bottom Left | Edit the distance from the photo eye to the centre of the detector |
| Bottom Right | Edit the units (in or mm) of the distance |

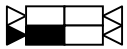
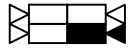

Photo Eye Distance

This distance refers to the distance from the infeed photo eye to the **centre** of the detector.

Press the soft key to edit the photo eye distance.



Units

The units for the distance can be inches (in) or millimetres (mm).

Press the soft key to change the distance units.

BELT SPEED SETUP

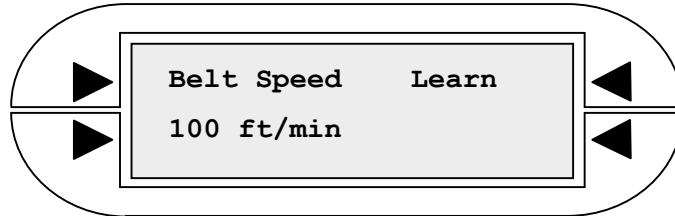

Menu Key > Soft Key 3 > Menu Key X 2 > Soft Key 4 > Menu Key

| Soft Key | Function |
|--------------|---|
| Top Left | Not used |
| Top Right | Jump to the Belt Speed Estimate Menu |
| Bottom Left | Edits the speed of the belt |
| Bottom Right | Edits the units of the belt speed (ft/min or m/min) |

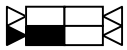

Belt Speed

The speed of the belt is used for reject timing purposes. It allows the detector to keep track of products passing through it.

Press the soft key to edit the speed of the Belt in *feet per minute* or *meters per minute*.

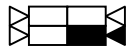

Units

Toggle the units of the belt speed between feet per minute or meters per minute.

PACKAGE LENGTH SETUP

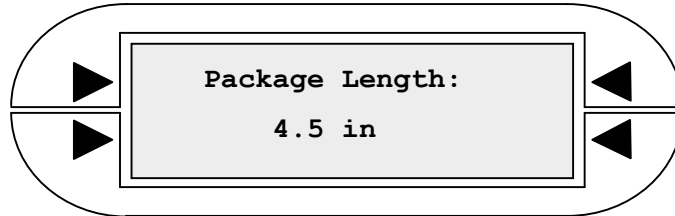

Menu Key > Soft Key 3 > Menu Key X 2 > Soft Key 4

| Soft Key | Function |
|--------------|---|
| Top Left | Not used |
| Top Right | Not used |
| Bottom Left | Edit Package Length |
| Bottom Right | Edit the units (in or mm) of the length |

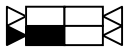

Package Length

Press the soft key to edit the length (in the direction of travel of the belt) of the package in inches or millimetres. This is typically set to the length of the largest package.

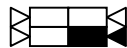

Units

The units for the length can be inches (in) or millimetres (mm).

Press the soft key to change the length units.

PHOTO EYE BLOCK LIMIT SETUP

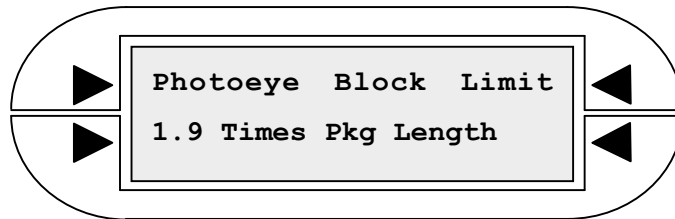

Menu Key > Soft Key 3 > Menu Key X 2 > Soft Key 4 > Menu Key X 3

| Soft Key | Function |
|--------------|-----------------------|
| Top Left | Not used |
| Top Right | Not used |
| Bottom Left | Edits the block limit |
| Bottom Right | Edits the block limit |



Block Limit

The photo block limit is used to prevent an obstructed photo eye from causing improper operation of the reject device. If the blocking Length exceeds the limit, a fault will occur.

Press one of these soft keys to edit the blocking length.

MINIMUM PACKAGE GAP

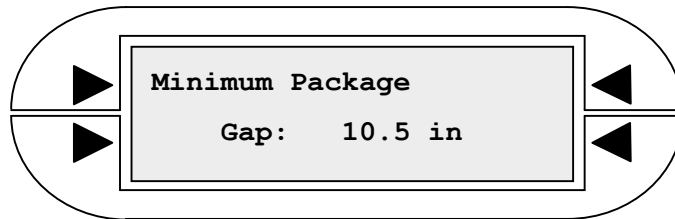

Menu Key > Soft Key 3 > Menu Key X 2 > Soft Key 4 > Menu Key X 4

| Soft Key | Function |
|--------------|---|
| Top Left | Not used |
| Top Right | Not used |
| Bottom Left | Edits the minimum package gap distance |
| Bottom Right | Edit the units (in or mm) of the gap distance |

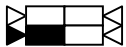

Minimum Package Gap

This should be set to the minimum gap distance between packages on the line. The detector will assume that packages that are closer together than the gap distance are a single pack. Some packages may cause the photo eye to produce spurious pulses because of seams or partially transparent materials. This parameter helps to “de-bounce” the photo eye signal.

Press the soft key to edit the minimum package gap distance.

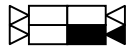

Units

The units for the gap distance can be inches (in) or millimetres (mm).

Press the soft key to change the gap distance units.

REJECT WITH NO RUNNING PRODUCT

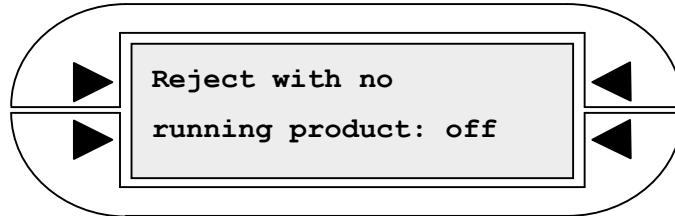

Menu Key > Soft Key 3 > Menu Key X 2 > Soft Key 4 > Menu Key X 5

| Soft Key | Function |
|--------------|--|
| Top Left | Not used |
| Top Right | Not used |
| Bottom Left | Not Used |
| Bottom Right | Toggles rejection without product On/Off |



Reject with no running product

When set to *on*, this will allow the reject device to be activated on detection even when the infeed photo eye has not seen a package. When *off*, the reject device will only activate if a package was seen by the infeed photo eye.

REJECT CHECK

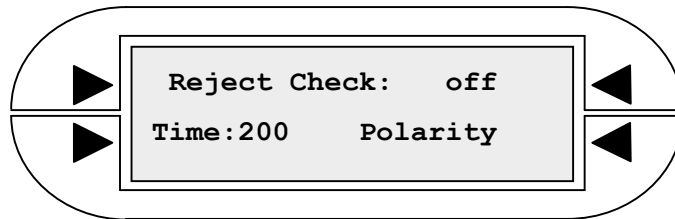

Menu Key > Soft Key 3 > Menu Key X 3

| Soft Key | Function |
|--------------|--|
| Top Left | Not used |
| Top Right | Cycles through reject check modes |
| Bottom Left | Edits the Confirmation time |
| Bottom Right | Goes to Reject Check Photo Eye Polarity Setup Menu |

Reject Confirmation

When a reject device is being used, it is desirable to confirm its proper operation. Most reject devices can be equipped to return a reject confirmation signal to the detector.



Reject Check

Press the soft key to enter the option field and set the reject check to one of the following options:

- Off - Reject Check is off
- 1 - One sensor is used to confirm that the reject device activated and that the product has been rejected.
- 2 - Two sensors are used to confirm that the reject device has activated and that it has returned to its starting position.

Examples of confirmation sensors are photocells, limit switches, proximity sensors, etc...

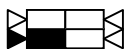

Confirmation Time

Press the soft key to set the confirmation time.

The confirmation time is the time (uses the in internal clock which has 231 pulses per second) for the reject device to extend and retract. The reject confirmation sensor must detect that the contaminated product was rejected within this time. Exceeding this threshold will result in a fault.

REJECT CONFIRM POLARITY SETUP

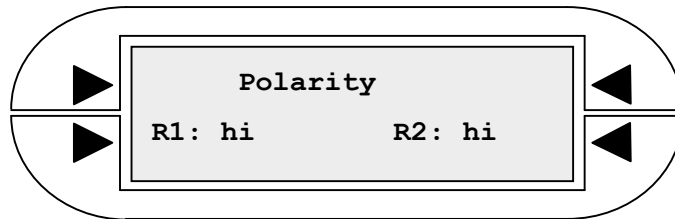

Menu Key > Soft Key 3 > Menu Key X 3 > Soft Key 4

| Soft Key | Function |
|--------------|--|
| Top Left | Not used |
| Top Right | Not used |
| Bottom Left | Toggles the polarity of the first reject confirm sensor |
| Bottom Right | Toggles the polarity of the second reject confirm sensor |

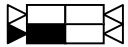

Reject Confirm Sensor 1 Polarity

Low – Reject confirm sensor should read low when the reject is not activated.

Hi – Reject confirm sensor should read hi when the reject is activated and in the reject position.

Press the soft key to invert the polarity of the second reject confirmation photo-eye.

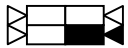

Reject Confirm Sensor 2 Polarity

Low – Reject confirm sensor should read low when the reject is not activated.

Hi – Reject confirm sensor should read hi when the reject is activated and in the reject position.

Press the soft key to invert the polarity of the second reject confirmation photo-eye.

MANUAL REJECT

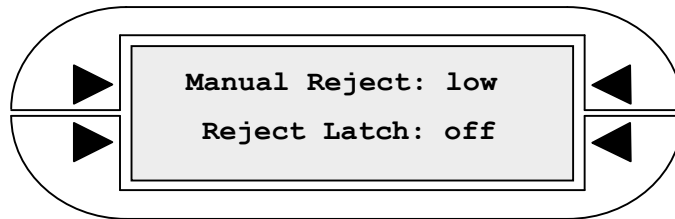

Menu Key > Soft Key 3 > Menu Key X 4

| Soft Key | Function |
|--------------|--|
| Top Left | Not used |
| Top Right | Toggles manual reject hi/low |
| Bottom Left | Not used |
| Bottom Right | Toggles Reject Latch mode between on and off |

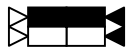

Manual Reject

Manual rejection is used to ensure the proper functioning of the reject device. It allows manual activation of the reject device. This can be used for troubleshooting.

Hi - Reject device is activated.

Low - Reject device is not activated.

Press the soft keys to activate and deactivate the reject device.

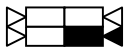

Reject Latch

When set to on, the reject relay will stay latched in the reject position until the operator manually clears the latch from a menu prompt. This can be used with any reject mode.

Press the soft key to toggle between on and off.

PASSWORD

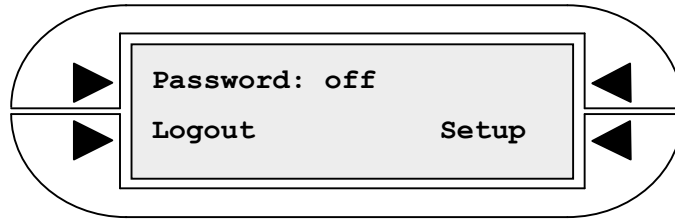

Menu Key X 2

| Soft Key | Function |
|--------------|----------------------------------|
| Top Left | Toggles Password Security On/Off |
| Top Right | Toggles Password Security On/Off |
| Bottom Left | Logs user out |
| Bottom Right | Goes to Password setup Menu |



Password Protection

Password protection prevents an unauthorized user from tampering with the metal detector settings.

Press one of these soft keys to enable or disable password protection.



Log Out

Logout reinstates password protection after you have completed adjustments to the metal detector settings. Password protection will be reinstated if no key press has occurred for 5 minutes.

NOTE: THE DEFAULT PASSWORD IS "AAAA"

When password Protection is on, the display shown below will appear upon any key press.

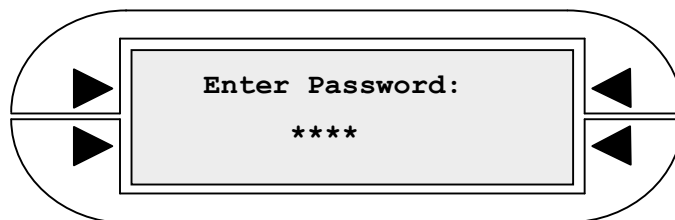

If you forgot your password the detector will display a seed number, which Fortress engineers can decode for you. Please be prepared to offer proof of your authority.

CHANGE PASSWORD

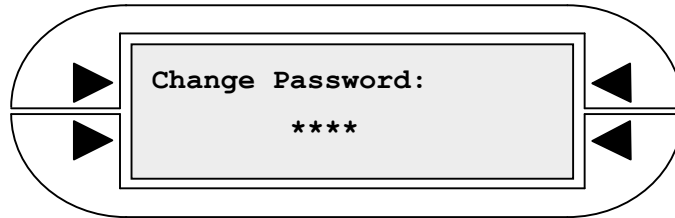

Menu Key X 2 > Soft Key 4

| Soft Key | Function |
|--------------|------------------|
| Top Left | Not used |
| Top Right | Not used |
| Bottom Left | Changes Password |
| Bottom Right | Changes Password |

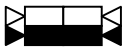

Changing Password

This menu is used to change the password. A password can be made up of any four alphabetical, numerical characters and the underscore (_) character.

Press one of the soft keys to change the password. Make sure you record the password in a safe place.

PASSWORD HARD KEY ACCESS SETUP



Menu Key X 2 > Soft Key 4 > Menu Key

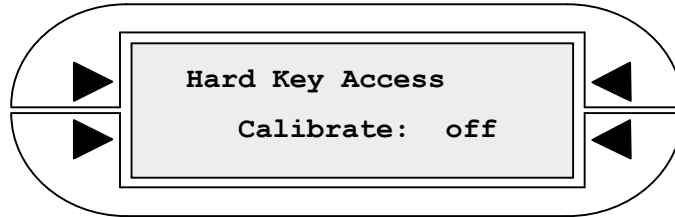

Menu Key X 2 > Soft Key 4 > Menu Key X 2

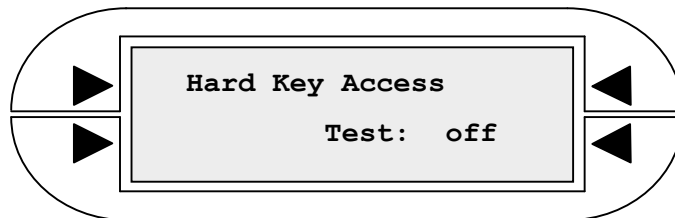

Menu Key X 2 > Soft Key 4 > Menu Key X 3

| Soft Key | Function |
|--------------|-----------------------------------|
| Top Left | Not used |
| Top Right | Not used |
| Bottom Left | Not used |
| Bottom Right | Toggle the hard key access on/off |

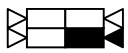

Hard Key Password Access

It is possible to allow operators to press the SELECT PRODUCT, CALIBRATE and TEST hard keys without a password, while the reset of the menu system remains password protected.

When “on”, an operator can perform the designated function without needing to enter a password.

Press the soft key to toggle hard key access on/off.

PASSWORD FUNCTION SETUP

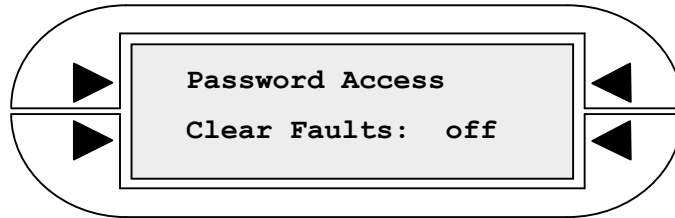

Menu Key X 2 > Soft Key 4 > Menu Key X 4

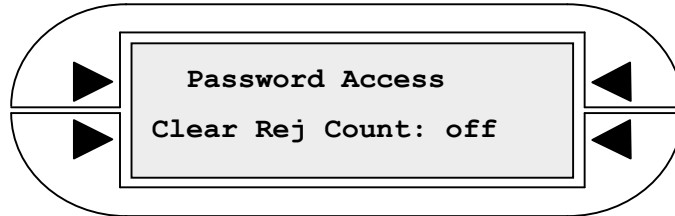

Menu Key X 2 > Soft Key 4 > Menu Key X 5



Menu Key X 2 > Soft Key 4 > Menu Key X 6

| Soft Key | Function |
|--------------|-------------------------------|
| Top Left | Not used |
| Top Right | Not used |
| Bottom Left | Not used |
| Bottom Right | Toggle soft key access on/off |

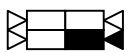

Soft Key Password Access

It is possible to allow operators to clear faults, or clear the reject count without a password, while the reset of the menu system remains password protected.

When "on", an operator can perform the designated function without needing to enter a password.

Press the soft key to toggle soft key access on/off.

DIGITAL FILTER MENU

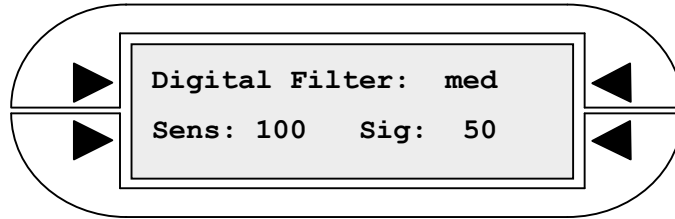

Menu Key X 3

| Soft Key | Function |
|--------------|--|
| Top Left | Not used |
| Top Right | Cycle through the digital filter options |
| Bottom Left | Edit the sensitivity |
| Bottom Right | Reset the signal peak |

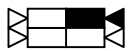

Digital Filter

This menu is used to choose between a number of different digital filters that are used to reduce noise caused by external sources. The most appropriate filter to choose is a function of product speed and the type of noise present.

Slow – A slow speed filter will be used to reduce noise, used for slow (below 20 feet/minute) conveyor applications.

Medium – An average speed filter will be used to reduce noise, used for typical conveyor applications.

Fast – A fast speed filter will be used to reduce noise, used for gravity systems.

Off - digital filter is not enabled

N1 to N11 – These filters are used for severe noise sources and vary in speed from N1, which is the fastest settings to N11, which is the slowest setting.

Press the soft key to select the filter option and press ENTER to accept it.

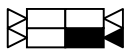

Signal Peak Reset

Press the soft key to reset the signal peak

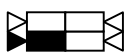

Sensitivity

See the Sensitivity Menu for a description of this field.

Press the soft key to edit the value in this field using the '+' and '-' keys.

LANGUAGE SELECTION

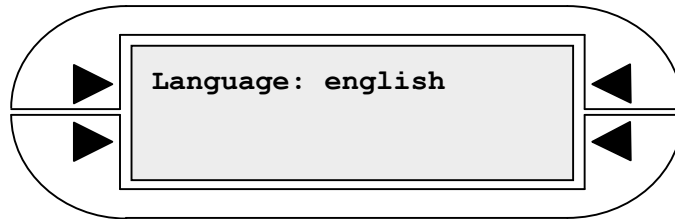

Menu Key X 4

| Soft Key | Function |
|--------------|--------------------------|
| Top Left | Cycles through languages |
| Top Right | Cycles through languages |
| Bottom Left | Not used |
| Bottom Right | Not used |



Language Selection

The Phantom user interface supports different languages.

Currently available languages are listed below;

- English
- French
- German
- Italian
- Spanish

Press one of the soft keys to select the desired language.

PACK COUNT DISPLAY

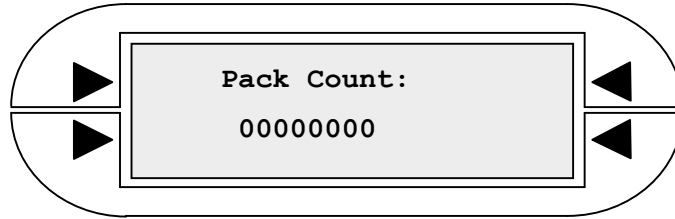

Menu Key X 5

| Soft Key | Function |
|--------------|------------------------|
| Top Left | Not Used |
| Top Right | Not Used |
| Bottom Left | Not used |
| Bottom Right | Soft key reset counter |



Pack Count Display Counter

Reject Mode must be photo or reverse for the pack counter display to work.

Pack Count display the number of product that passes through the metal detector (must break an in-feed photo eye)

FAULT SETUP MENU

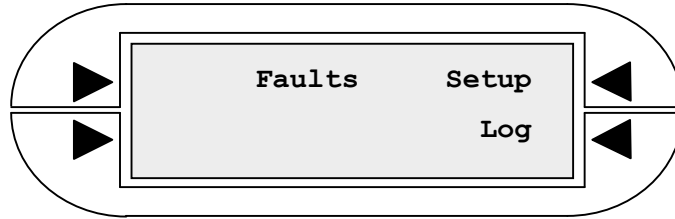

Menu Key X 6

| Soft Key | Function |
|--------------|-----------------------------------|
| Top Left | Not used |
| Top Right | Jump to the Fault Setup sub-menus |
| Bottom Left | Not used |
| Bottom Right | Jumps to fault log screen |



Fault Setup

Press the soft key to jump to the Fault Source Setup sub-menus.

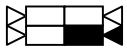

Fault Log

Press the soft key to jump to the Fault log screen.

REJECT ON FAULT MENU

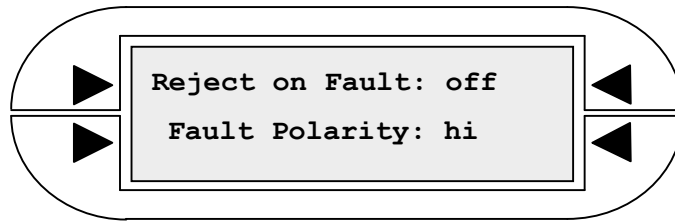

Menu Key X 6> Soft Key 3

| Soft Key | Function |
|--------------|---|
| Top Left | Not used |
| Top Right | Toggle the 'Reject on Fault' between 'on' and 'off' |
| Bottom Left | Not used |
| Bottom Right | Toggle the Fault Output polarity between 'hi' and 'low' |

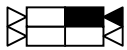

Reject on Fault

A fault condition will always cause the Fault Output to be activated. This menu can be used to activate the Reject Output as well as the Fault Output. When this field is set to 'on' any fault condition will cause both the Reject Output and the Fault Output to activate. When set to 'off', the Reject Output will not be affected by a fault condition.

Off - Reject output is not affected by a fault condition.

On - Reject output will activate while a fault condition is present.

Press the soft key to toggle between 'on' and 'off'.

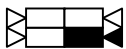

Fault Polarity

This menu is used to invert the Fault Output polarity.

low - Fault Output is closed during a fault condition.

hi - Fault Output is open during a fault condition. This polarity is fail safe.

Press the soft key to toggle between 'hi' and 'low'.

FAULT LATCH MENU

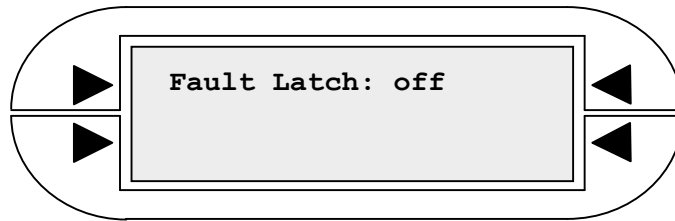

Menu Key X 6 > Soft Key 3 > Menu Key

| Soft Key | Function |
|--------------|---|
| Top Left | Not used |
| Top Right | Toggle the 'Fault latch' between 'on' and 'off' |
| Bottom Left | Not used |
| Bottom Right | Not used |



Fault Latch

When this field is set to 'on' any fault condition will need to be cleared manually by the operator. When 'off' some fault condition automatically cleared when the fault condition is cleared (sample photo-eye blocked)

Off - Fault latch off, some fault automatically cleared

On - Fault latch on, fault manually cleared by operator

Press the soft key to toggle between 'on' and 'off'.

FAULT SOURCE SETTINGS

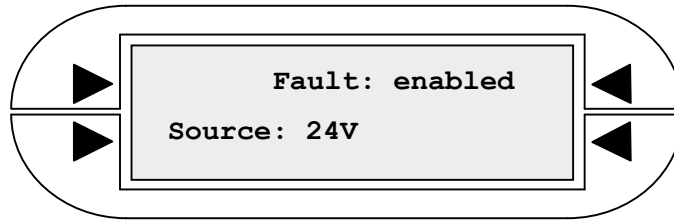

Menu Key X 6 > Soft Key 3 > Menu Key X 2

| Soft Key | Function |
|--------------|--|
| Top Left | Not used |
| Top Right | Toggles Fault setting 'masked' and 'enabled' |
| Bottom Left | Not used |
| Bottom Right | Toggles the Fault source |

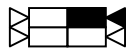

Fault Source Settings

Refer to list of Faults,

Masked - This fault source is masked, the input is ignored .

Enabled - The fault source is enabled, this in turn will enable a reject if the reject on fault is enabled.

Press the soft keys to toggle between 'masked' and 'enabled'.

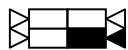

Fault Source Settings

Refer to list of Faults,

Press the soft keys to toggle between the list of fault source.

EXCESS REJECT SETUP

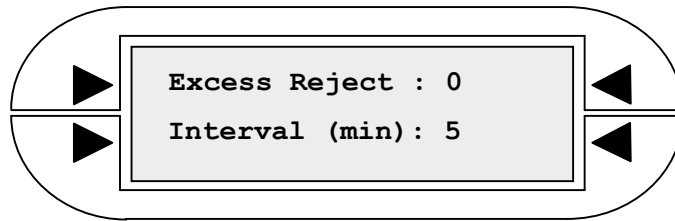

Menu Key X 6 > Soft Key 3 > Menu Key X 3

| Soft Key | Function |
|--------------|--|
| Top Left | Not used |
| Top Right | Edit the Excess Reject count threshold value |
| Bottom Left | Not used |
| Bottom Right | Edit the time interval for allowable rejects |

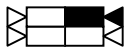

Excess Reject Count

This menu allows one to generate a fault condition if too many rejects occur in a specified time interval. This field is used to set the number of rejects that, if exceeded in the given time interval, will cause a fault condition. If this field is set to 0, then this fault source will be ignored.

Press the soft key to edit the value in this field using the '+' and '-' keys.

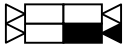

Time Interval

This field is used to set the time interval in minutes for the Excess Reject count. If the reject count is exceeded in this time interval a fault condition will occur.

Press the soft key to edit the value in this field using the '+' and '-' keys.

FAULT LOG MENU

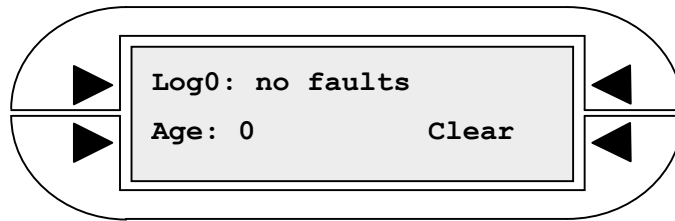

Menu Key X 6 > Soft Key 3 > Menu Key X 4 or Menu Key X 6 > Soft Key 4

| Soft Key | Function |
|--------------|--|
| Top Left | Not used |
| Top Right | Browse logged faults |
| Bottom Left | Display time passed of displayed fault |
| Bottom Right | Clear the fault log |

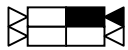

Fault log

Display the logged fault, press soft key to browse thru the fault logged.
Maximum number of fault that can be logged is 3.

Press the soft key '+' and '-' keys, to browse the logs

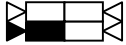

Age

Display the time passed in minutes of the displayed fault.

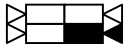

Clear

This field is used to clear the logged faults. Press the soft key clear the log.

APPENDICES

| No. | Description | Reference | No. Pages |
|-------------------|--|-----------|-----------|
| A | Board Maps and Electrical Wiring Diagram | | 5 |
| B | Troubleshooting Guide | | 1 |
| C | Failsafe System | | 3 |
| D | Spare Part List | | 2 |
| E | Equipment History Log | | 1 |
| F | | | |
| G | | | |
| H | | | |
| I | | | |
| J | | | |
| Comments : | | | |

Signed : _____

Date : _____

A. Board Maps and Wiring Diagrams

DSP MAP SD003 VER 3

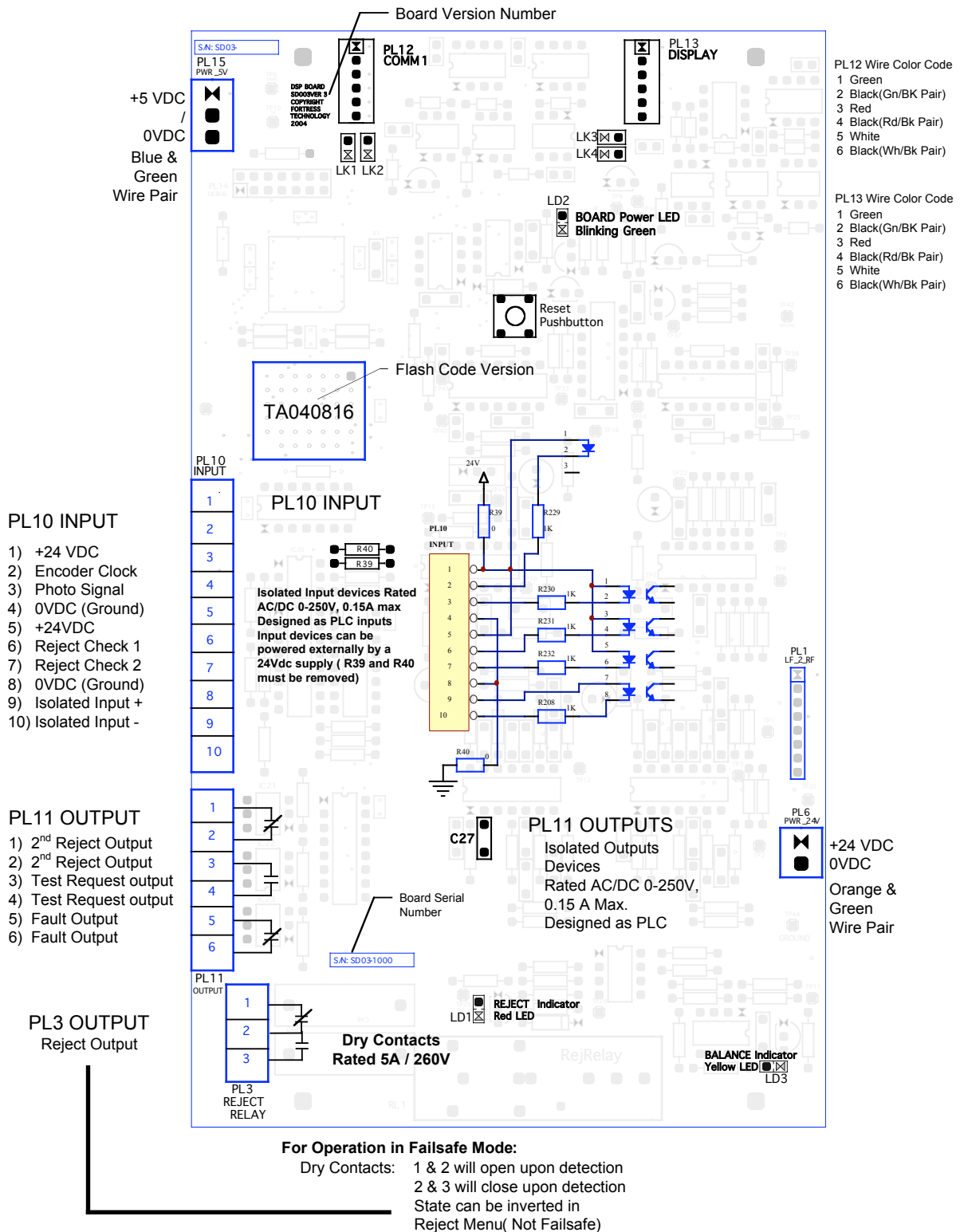

DISPLAY BOARD

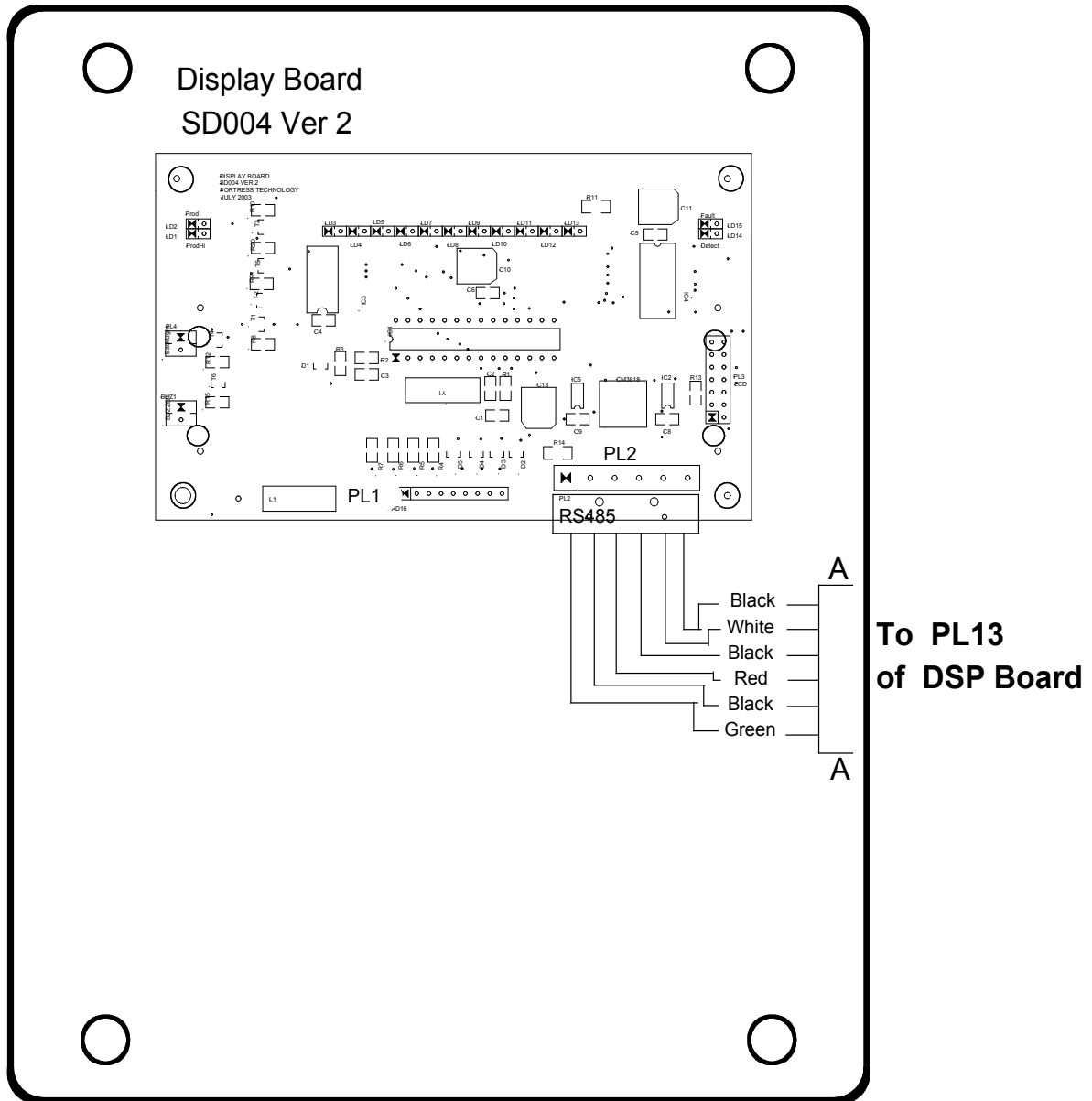

POWER SUPPLY AND WIRE COLOR CODE

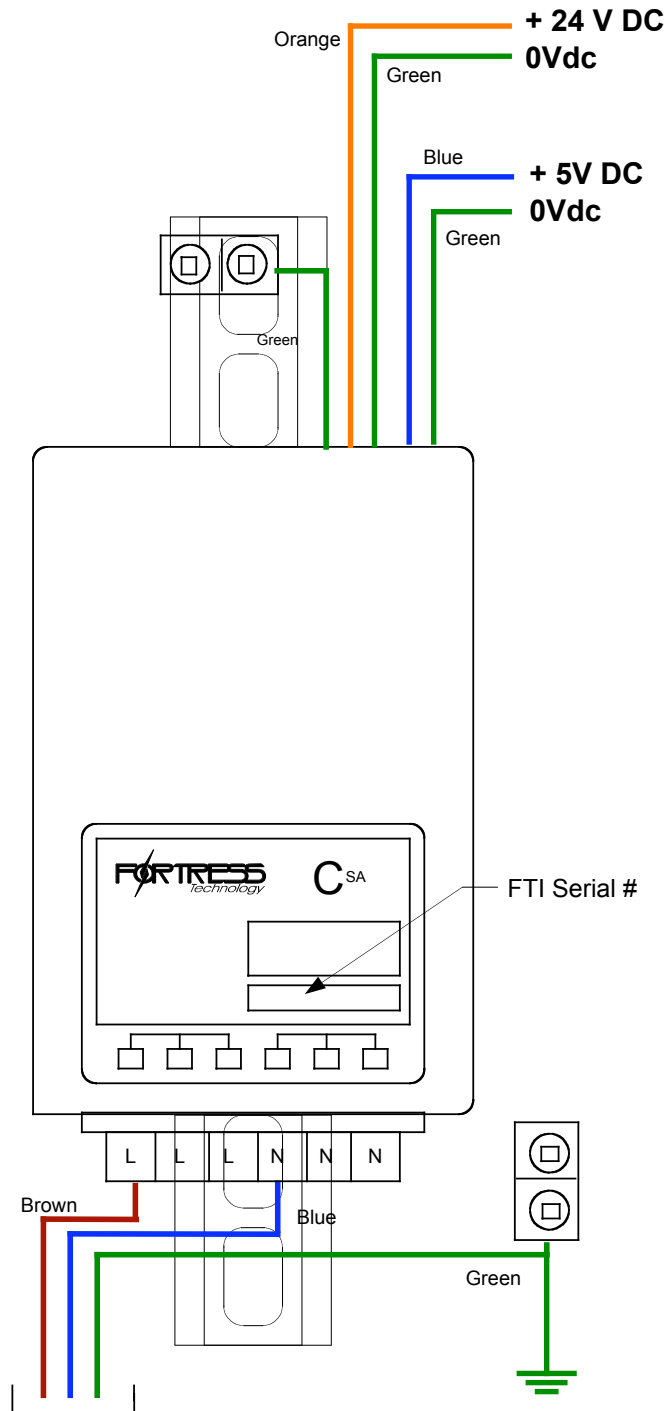

Part # PSU-U24/5-017-01R
Incoming Power 100-250 Vac.,
50/60Hz , 1.7 Amp, 40W

TYPICAL INPUT WIRING – SD003 VER 3.0

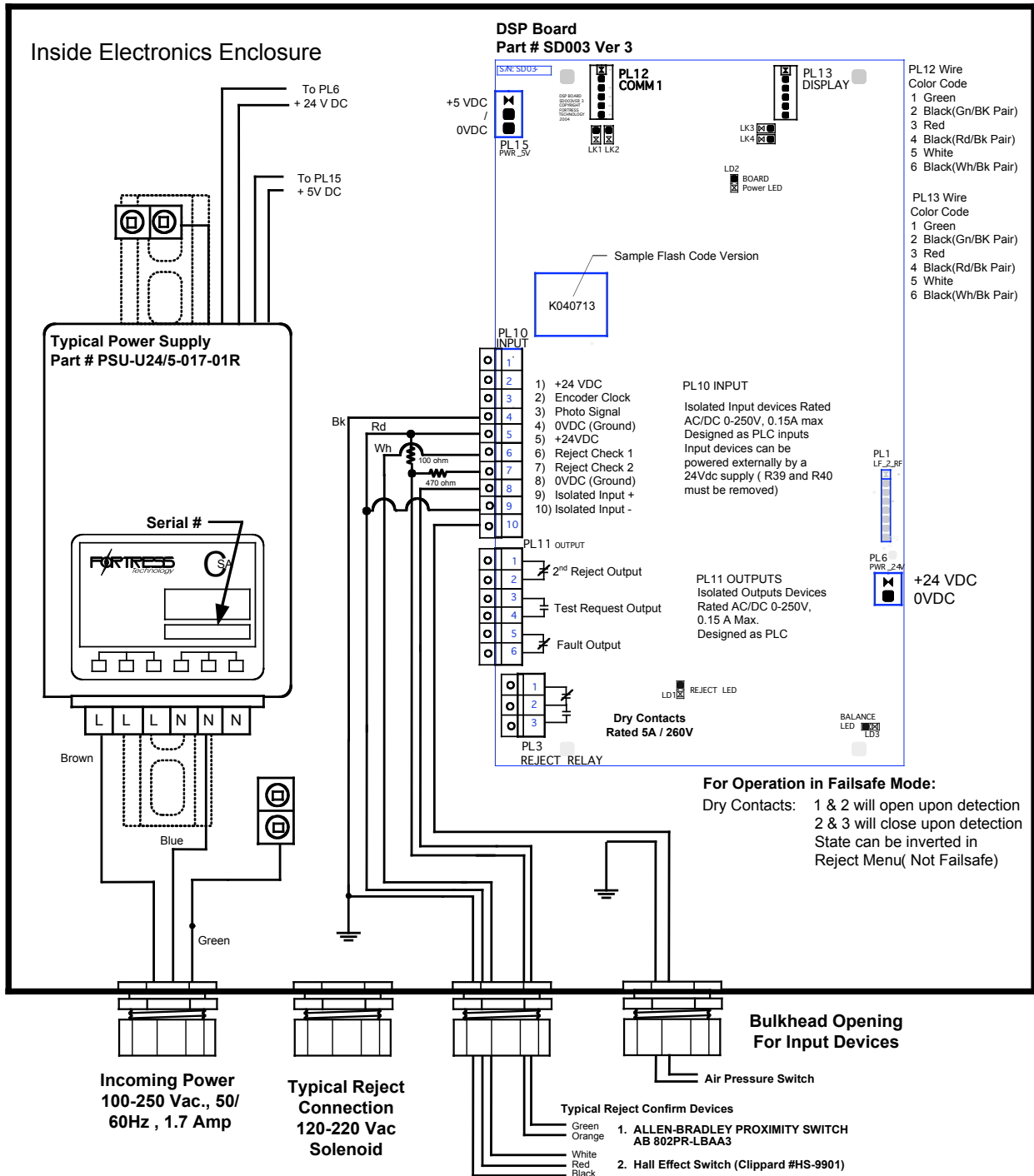

TYPICAL REJECT DEVICE WIRING – SD003 VER 3.0

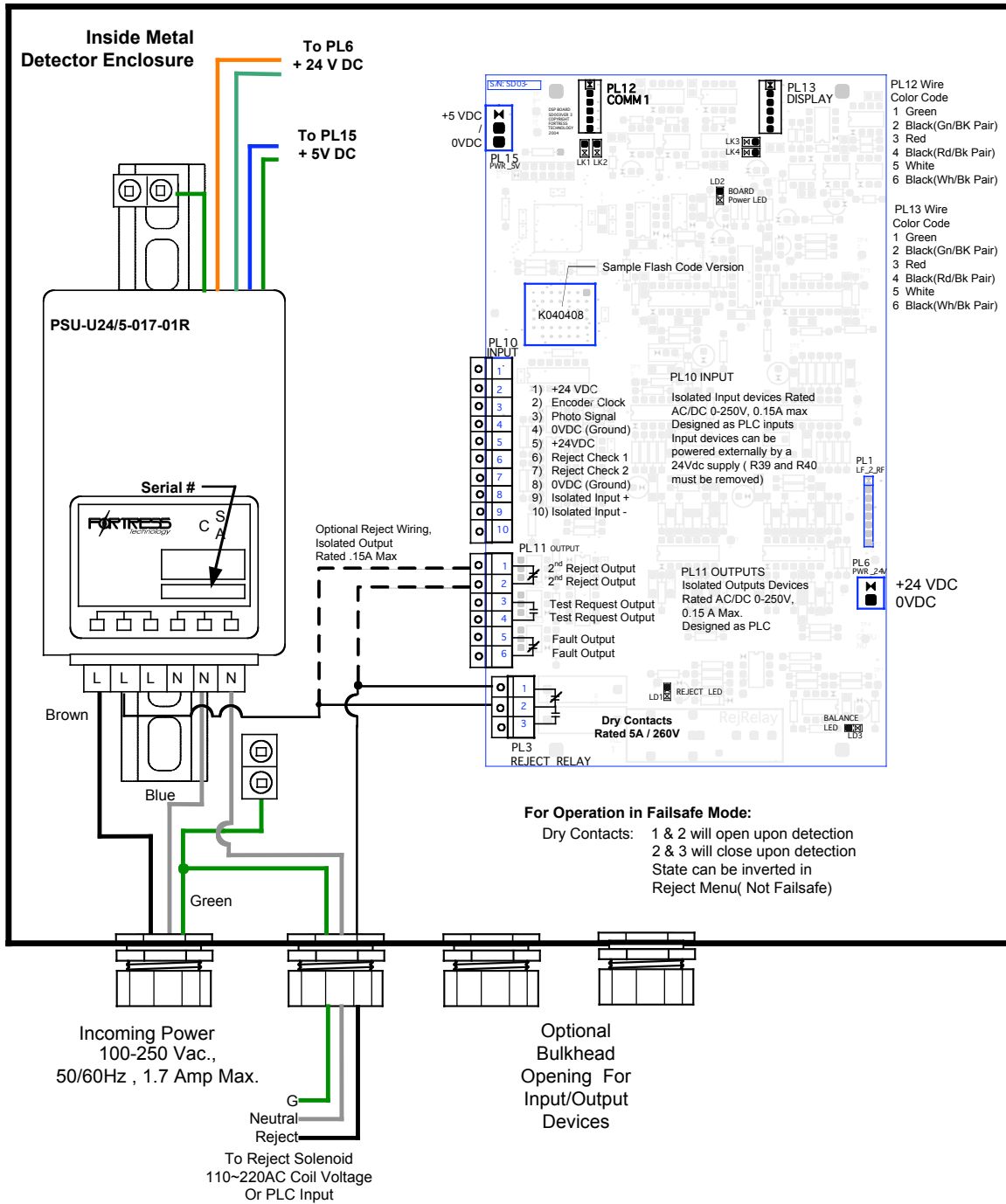

1. Do not use the detector's 24 volt supply to power auxiliary devices
2. It is recommended to use a clean and stable line supply which has no heavy inductive loads being switched.
3. All cables entering the enclosure must pass through a CSA/UL approved Strain Relief Bushing.

B. Troubleshooting Guide

WARNING! Shock Hazards
Only qualified service personnel should open the detector cover
Details of the Electrical Wiring can be found in [Appendix A](#)

1) Start Up

- Upon initial start up, if the display does not light up, make sure there is power going in the detector.
- If power is hooked up and there is still no display, open up the cover of the detector and check if the DSP board green LED(LD2) light is flashing
- If the DSP board green LED is not flashing check for loose cable connection (PL15) and measure with voltmeter TP6 (Digital ground) and TP10 (5 volts)
- If 5 volts is present and DSP board LED (LD2) is flashing, check for loose display cable connection (PL13) and also check the orientation of wire, on the DSP board side, from top orientation should be [green, black, red, black, white, black] wires. On the display side, the orientation should be [green, black, red, black, white, black]. Refer to [Appendix A](#)
- If problem persist please contact us for assistance.

2) On Operation

- If the reject interface is malfunctioning, check if the reject cable from the detector is properly wired to the packaging system or PLC input/output connectors.
- If the reject device uses a diverter valve, when the test key is pressed the valve should activate, this would indicate if the solenoid is working properly.
- Note the DSP board reject uses a mechanical relay(dependent on the actual installed relay on the board some uses solid state relay), Perform a continuity test on the reject cable coming out of the detector or measure the voltage across pin 2 & 3 of PL3
- If problem persist contact us for assistance.

3) False Triggers

- Reboot the system by powering it down for 2 mins and power it up and perform initial setup procedure, to revert back to factory setup. Perform test procedure and observe the metal detector for any false triggering.
- When no product is running and the detector is false triggering. Check and clean the pipe system specially the nylon pipe that is running through the aperture of the detector. Make sure that pipe is totally clear of any sludge clinging to the wall of the pipe. Perform start up procedure.
- If problem persists, check the sensitivity and calibration setting of the detector, it might be cranked up too high that the detector is too sensitive or the detector is out of phase and need calibration. Reset the system by disconnecting power for 2 minutes and powering it back up for test. Perform a manual calibration to learn the phase of metal detector casing.
- If problem still persists contact us for assistance.

C. Spare Parts List

TYPICAL VERTEX MODEL

| Part Number | Description |
|----------------------------|---|
| PSU-U24/5-017-01R | Power Supply Universal 100~240V Voltage Output: +24Vdc, +5Vdc @ 1.7Amp 47-63Hz, 40W Max |
| SD001 Rev 4.3 | Search Head PCB |
| SD003 Rev 3.0 | DSP PCB - Phantom |
| CP-S101S-A01E | Display Unit Phantom - Control Panel Standard Membrane: Regular English |
| TEST-WAND-XXX-##.## | Test Wand ##.## mm.(call for Sphere size availability) XXX – FE/ NFE / SS |
| TEST-BALL-XXX-##.## | Test Ball ##.## mm.(call for Sphere size availability) XXX – FE/ NFE / SS |

SAMPLE REQUEST FORM

When Requesting for Spare parts or any technical assistance please provide the necessary information to facilitate quick processing time

Contact Information:

Contact Name: _____
Company Name: _____
Company Address: _____
Phone: _____
FAX: _____
Email Address: _____

- Request For Spare Parts
 Request for Technical Assistance

Unit(s) Serial Number: typically located in the power supply unit

Details:

